

1 2 3 4 5 6 7 8

REVISIONS		
ISS	ZONE	DESCRIPTION\PER REQUEST\DATE

業務部

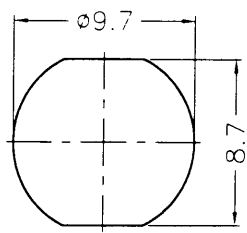

RECOMMENDED MOUNTING HOLE

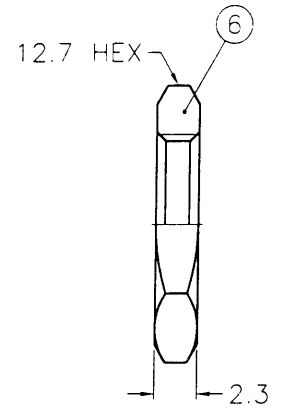
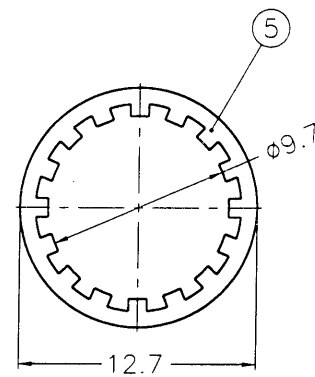
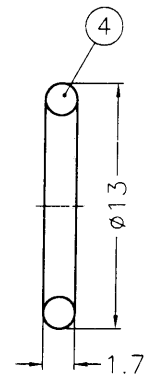
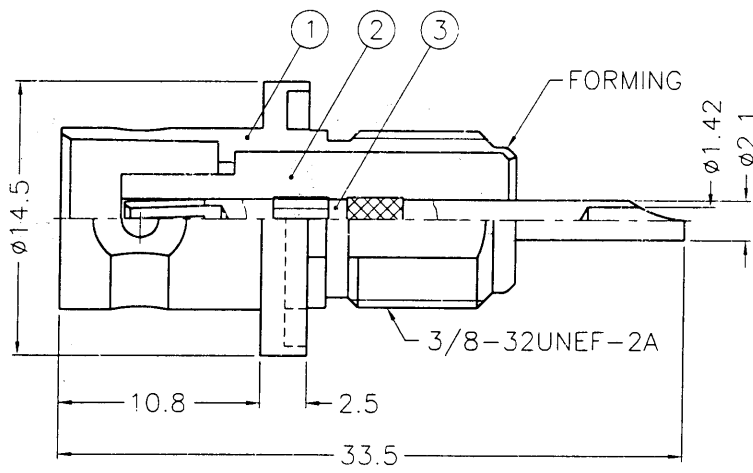

- NOTES: FINISH (PLATING THICKNESS IN MICRO-INCHES)
- BRASS PER QQ-B-626
  - BRASS PER QQ-B-613
  - NICKEL PL. 100 MIN. THICK OVER COPPER STRIKE
  - PHOSPHOR BRONZE PER QQ-B-750
  - GOLD PL. 30 MIN. THICK OVER NICKEL PL. 100 MIN. THICK OVER COPPER STRIKE
  - TEFLON MIL-P-19468



NO.	DESCRIPTION	MATERIAL	FINISH	Q'TY	DRAWING NO.	SCALE	ISSUE	DATE
6	HEX NUT	NOTE 1	NOTE 3	1	HN127-3/8-32 X23	2.5/1	A	03-23-99'
5	LOCK WASHER	NOTE 2	NOTE 3	1	LW-127/97X05			
4	GASKET	SILICONE	RED	1	GS-13/96XD17			
3	CONTACT PIN	NOTE 4	NOTE 5	1	B6351A2-001-3			
2	INSULATOR	NOTE 6	NATURAL	1	B6351A2-001-2T-50			
1	BODY	NOTE 1	NOTE 3	1	B6351A2-001-1			

DIMENSIONS ARE IN MILLIMETERS  
UNLESS OTHERWISE SPECIFIED TOLERANCES  
0.5-6 = ±0.2  
6-30 = ±0.4  
30-120 = ±0.6  
120-315 = ±1  
315-1000 = ±1.6  
1000-2000 = ±2.4

PART NO.  
APPROVED *Mark C* DATE 03-23-99'  
CHECKED *Mark C* DATE 03-23-99'  
DRAWN *Shaly.w* DATE 03-23-99'

**KAI JACK INDUSTRIAL CO., LTD.**  
TAINAN TAIWAN R.O.C.  
TITLE: BNC BULKHEAD RECEPT. JACK  
DRAWING NO.: KJ-B6351A2-001-NT30G-50  
FILE NO.: F:\DWG\B\6351A2\001\50\NT30G

F  
E  
D  
C  
B  
A

F  
E  
D  
C  
B  
A

8825270