

1 2 3 4 5 6 7 8

REVISIONS		
ISS	ZONE	DESCRIPTION\PER REQUEST\DATE
B	A-1	NO.2 WAS CHANGED\RD-DM88020401C\02-04-99'

業務部

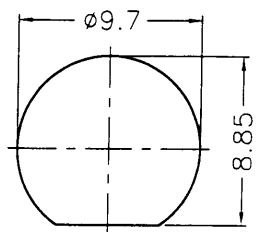

RECOMMENDED MOUNTING HOLE

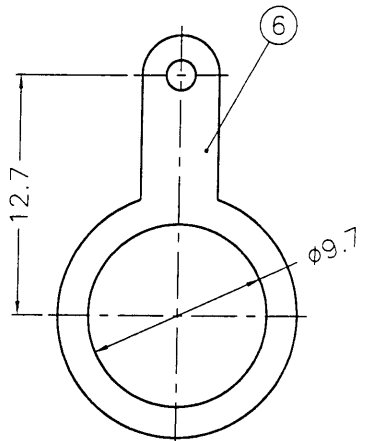
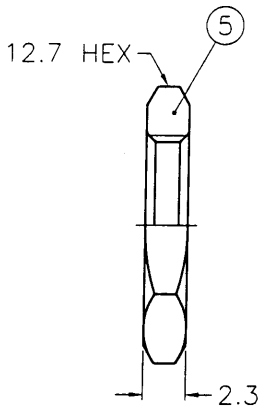
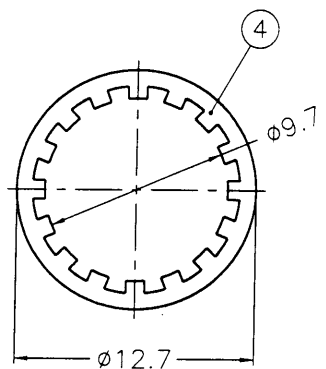
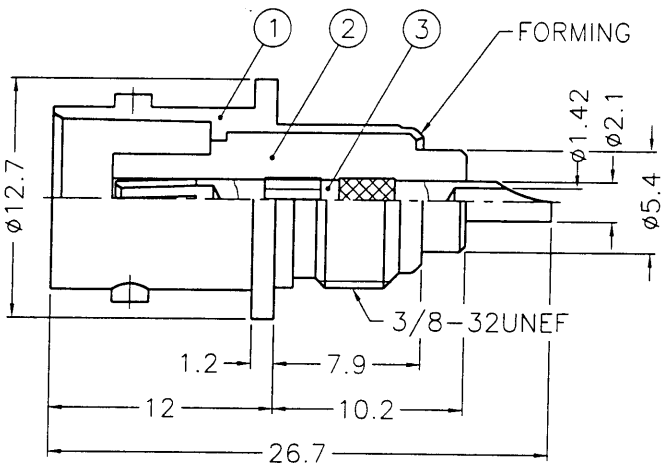

NOTES: FINISH (PLATING THICKNESS IN MICRO-INCHES)  
 1. BRASS PER QQ-B-626  
 2. BRASS PER QQ-B-613  
 3. NICKEL PL. 100 MIN. THICK OVER COPPER STRIKE  
 4. PHOSPHOR BRONZE PER QQ-B-750  
 5. GOLD PL. 3 MIN. THICK OVER NICKEL PL. 100 MIN. THICK OVER COPPER STRIKE

88.2.09  
R & D

DIMENSIONS ARE IN MILLIMETERS					PART NO.		KAI JACK INDUSTRIAL CO., LTD. TAINAN TAIWAN R.O.C.				
6	SOLDER TAG	NOTE 2	NOTE 3	1	B7310-7	APPROVED	Mark. C	DATE	02-04-99'	TITLE	BNC BULKHEAD RECEPT. JACK
5	HEX NUT	NOTE 1	NOTE 3	1	HN127-3/8-32 X23	CHECKED	Mark. C	DATE	02-04-99'	DRAWING NO.	KJ-B6351B1-ND3G-50
4	LOCK WASHER	NOTE 2	NOTE 3	1	LW-127/97X05	DRAWN	Ada	DATE	02-04-99'	FILE NO.	F:\DWG\B\6351B1\50\ND3G
3	CONTACT PIN	NOTE 4	NOTE 5	1	B7310-3-50						
2	INSULATOR	DELTRIN	NATURAL	1	B7310-2-50-C						
1	BODY	NOTE 1	NOTE 3	1	B7310-1						
NO.	DESCRIPTION	MATERIAL	FINISH	Q'TY	DRAWING NO.	SCALE	2.5/1	ISSUE	B		

88215713