

ISS	ZONE	REVISIONS	DESCRIPTION \ PER REQUEST \ DATE

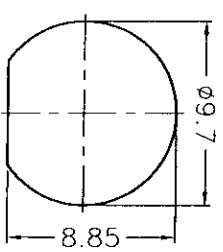

RECOMMENDED MOUNTING HOLE

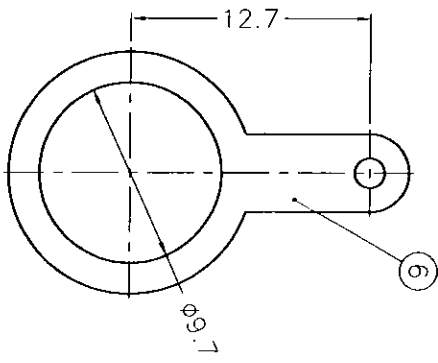
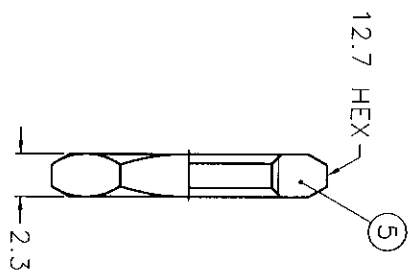
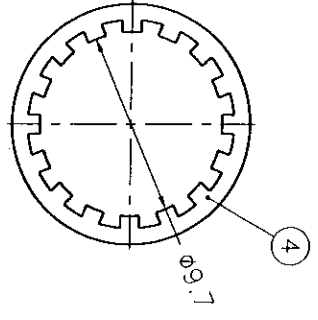
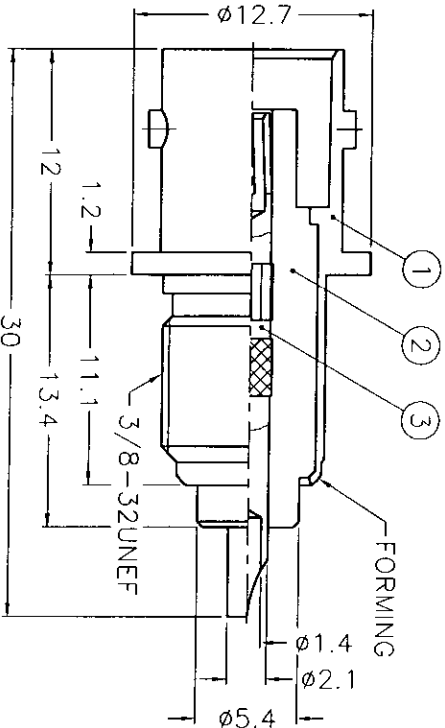

- NOTES: FINISH (PLATING THICKNESS IN MICRO-INCHES)
1. BRASS PER QQ-B-626
 2. BRASS PER QQ-B-613
 3. NICKEL PL. 100 MIN. THICK OVER COPPER STRIKE
 4. PHOSPHOR BRONZE PER QQ-B-750
 5. GOLD PL. 3 MIN. THICK OVER NICKEL PL. 100 MIN. THICK OVER COPPER STRIKE

6	SOLDER TAG	NOTE 2	NOTE 3	1	B7310-7
5	HEX NUT	NOTE 1	NOTE 3	1	HN127-3/8-32
					X23
4	LOCK WASHER	NOTE 2	NOTE 3	1	LW-127/97X05
3	CONTACT PIN	NOTE 4	NOTE 5	1	B7300-5
2	INSULATOR	DELFIN	NATURAL	1	B7311-2-50-C
1	BODY	NOTE 1	NOTE 3	1	B7311-1
NO.	DESCRIPTION	MATERIAL	FINISH	Q'TY	DRAWING NO.

DIMENSIONS ARE IN MILLIMETERS
UNLESS OTHERWISE SPECIFIED

TOLERANCES

0.5-6	= ±0.2
6-30	= ±0.4
30-120	= ±0.6
120-315	= ±1
315-1000	= ±1.6
1000-2000	= ±2.4

PART NO.

APPROVED DATE 02-04-99'

CHECKED DATE 02-04-99'

DRAWN DATE 02-04-99'



KAI JACK INDUSTRIAL CO., LTD.
TAINAN TAIWAN R.O.C.

TITLE
BNC BULKHEAD RECEIPT JACK

DRAWING NO. KJ-B6351B2-ND3G-50

FILE NO. F:\DWG\B6351B2\50\ND3G



1 2 3 4 5 6 7 8

882517