

1 2 3 4 5 6 7 8

REVISIONS		
ISS	ZONE	DESCRIPTION\PER REQUEST\DATE

SALES

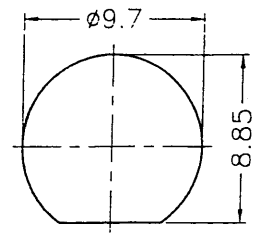

RECOMMENDED MOUNTING HOLE
(建議架設孔)

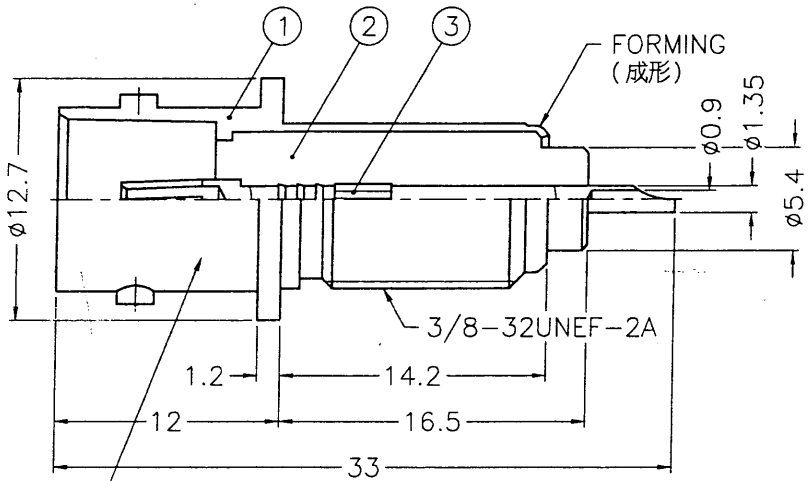

STAMP (IF ANY)
噴字 (若有要求)

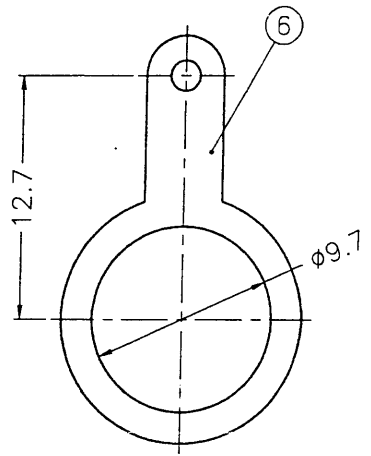
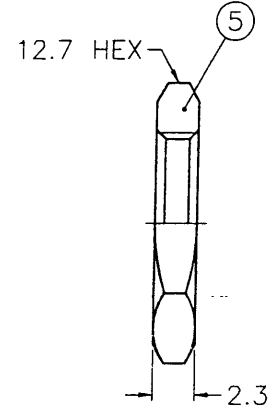
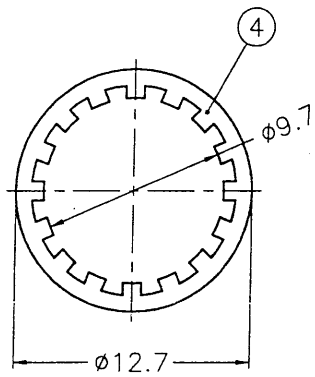

THIS DRAWING HAS APPROVED BY:

CUSTOMER SIGNATURE
DATE: _____

- NOTES: FINISH (PLATING THICKNESS IN MICRO-INCHES)
- BRASS PER QQ-B-626
 - BRASS PER QQ-B-613
 - NICKEL PL. 100 MIN. THICK OVER COPPER STRIKE
 - GOLD PL. 10 MIN. THICK OVER NICKEL PL. 100 MIN. THICK OVER COPPER STRIKE
 - PHOSPHOR BRONZE PER QQ-B-750
 - TEFLON MIL-P-19468

1. MAX. PANEL THICKNESS=9mm

DIMENSIONS ARE IN MILLIMETERS					PART NO.		Amphenol - Kai Jack										
6	SOLDER TAG	NOTE 2	NOTE 3	1	B7310-7	TAINAN TAIWAN											
5	HEX NUT	NOTE 1	NOTE 3	1	HN127-3/8-32 X23	APPROVED	DATE										
4	LOCK WASHER	NOTE 2	NOTE 3	1	LW-127/97X05	<i>A.K.C.</i>	03-14-02'										
3	CONTACT PIN	NOTE 5	NOTE 4	1	B7312-3-75	CHECKED	DATE										
2	INSULATOR	NOTE 6	NATURAL	1	B7312-2T-75	<i>Karl. J.</i>	03-14-02'										
1	BODY	NOTE 1	NOTE 3	1	B7312-1	DRAWN	DATE										
						<i>Karl. J.</i>	03-14-02'										
NO.	DESCRIPTION	MATERIAL	FINISH	Q'TY	DRAWING NO.	SCALE	2.5/1	ISSUE	A	FILE NO.	F:\DWG\B\6351B3\75\NT3G	TITLE	BNC BULKHEAD RECEPT. JACK	DRAWING NO.	KJ-B6351B3-NT10G-75	ITEM NO.	016

4
3
2
1
A

F
E
D
B

1 2 3 4 5 6