

1 2 3 4 5 6 7 8

REVISIONS		
ISS	ZONE	DESCRIPTION\PER REQUEST\DATE

業務部

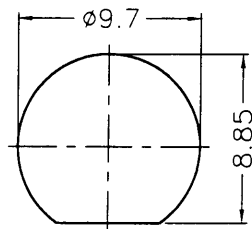

RECOMMENDED MOUNTING HOLE

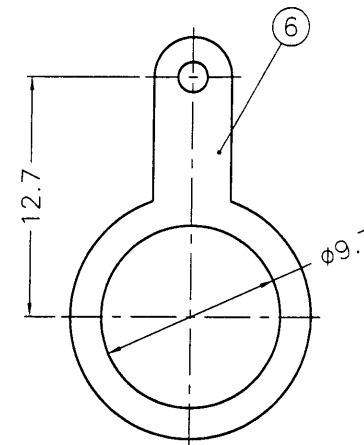
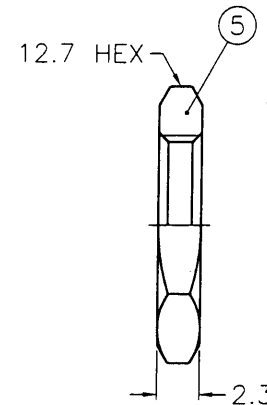
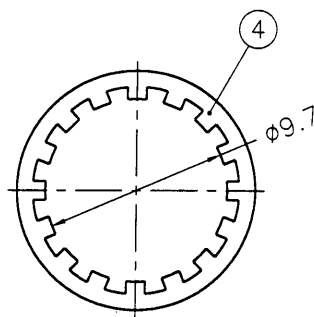
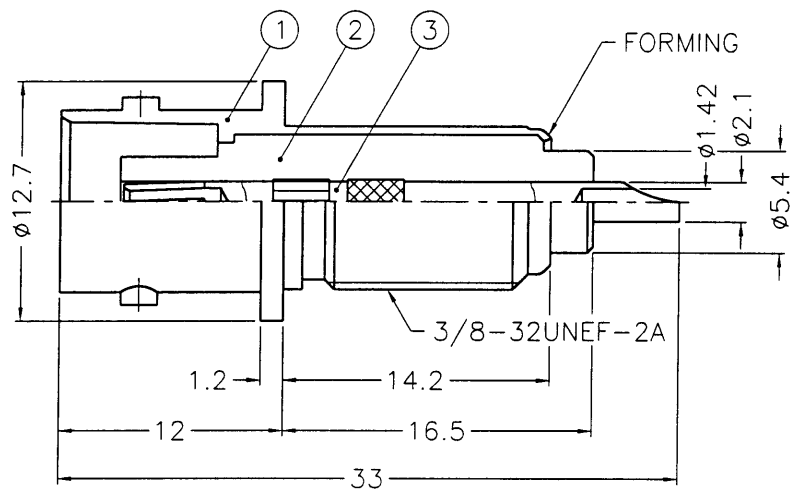

NOTES: FINISH (PLATING THICKNESS IN MICRO-INCHES)

- 1. BRASS PER QQ-B-626
- 2. BRASS PER QQ-B-613
- 3. NICKEL PL. 100 MIN. THICK OVER COPPER STRIKE
- 4. GOLD PL. 3 MIN. THICK OVER NICKEL PL. 100 MIN. THICK OVER COPPER STRIKE
- 5. PHOSPHOR BRONZE PER QQ-B-750
- 6. TEFLON MIL-P-19468



DIMENSIONS ARE IN MILLIMETERS					PART NO.		
6	SOLDER TAG	NOTE 2	NOTE 3	1	B7310-7		
5	HEX NUT	NOTE 1	NOTE 3	1	HN127-3/8-32 X23	APPROVED <i>Mark.C</i> DATE 02-04-99'	BNC BULKHEAD RECEPT. JACK
4	LOCK WASHER	NOTE 2	NOTE 3	1	LW-127/97X05	CHECKED <i>Mark.C</i> DATE 02-04-99'	DRAWING NO. KJ-B6351B3-NT3G-50
3	CONTACT PIN	NOTE 5	NOTE 4	1	B7312-3-50	DRAWN <i>Sola</i> DATE 02-04-99'	FILE NO. F:\DWG\B\6351B3\50\NT3G
2	INSULATOR	NOTE 6	NATURAL	1	B7312-2T-50-B		
1	BODY	NOTE 1	NOTE 3	1	B7312-1		
NO.	DESCRIPTION	MATERIAL	FINISH	Q'TY	DRAWING NO.	SCALE 2.5/1	ISSUE A

F
E
D
C
B
A

F
E
D
C
B
A

88125220