

1 2 3 4 5 6 7 8

REVISIONS		
ISS	ZONE	DESCRIPTION \ APPROVED \ DATE

業務部

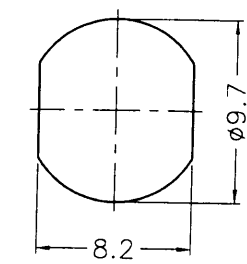

RECOMMENDED MOUNTING HOLE

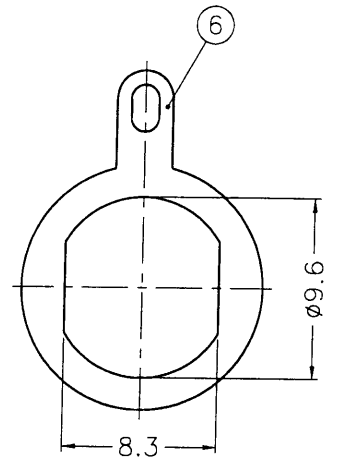
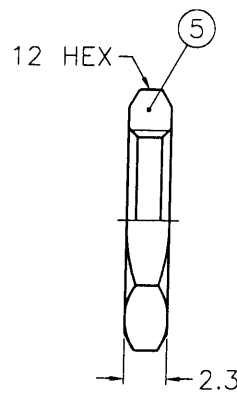
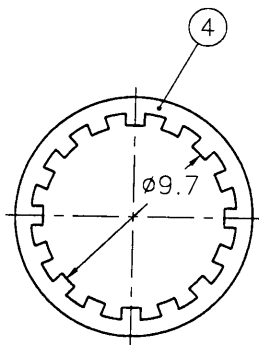
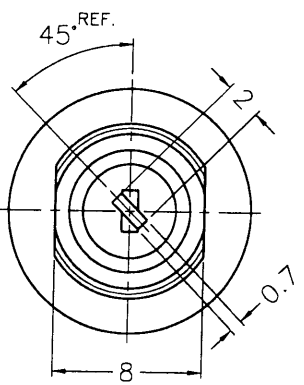
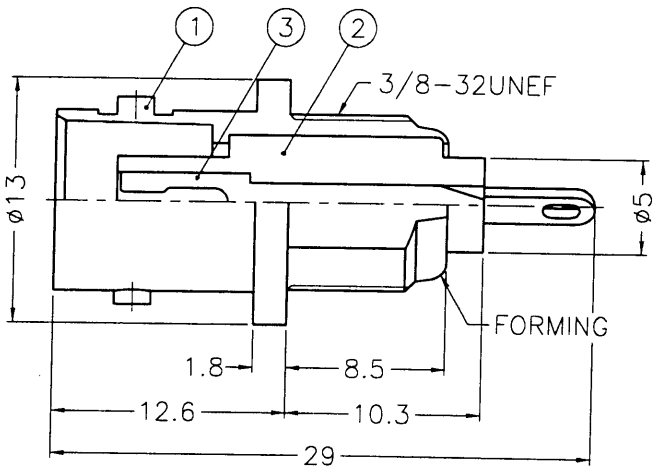

NOTES: FINISH (PLATING THICKNESS IN MICRO-INCHES)
 1. BRASS PER QQ-B-626
 2. BRASS PER QQ-B-613
 3. NICKEL PL. 100 MIN. THICK OVER COPPER STRIKE
 4. BRIGHT TIN PL. 100 MIN. THICK OVER NICKEL PL. 50 MIN. THICK OVER COPPER PL. 100 MIN. THICK
 5. NICKEL PL. 100 MIN. THICK OVER COPPER PL. 300 MIN. THICK

出圖
87.8.17
R&D

NO.	DESCRIPTION	MATERIAL	FINISH	Q'TY	DRAWING NO.
6	SOLDER TAG			1	B6351D1-6
5	HEX NUT			1	HN12-3/8-32X23
4	LOCK WASHER			1	LW-127/97X05
3	CONTACT PIN			1	B6351D1-23-50
2	INSULATOR	DELTRIN	NATURAL	1	
1	BODY	DIECAST	NOTE 5	1	B6351D1-1-B

DIMENSIONS ARE IN MILLIMETERS			
UNLESS OTHERWISE SPECIFIED TOLERANCES			
0.5-6	=	±0.2	
6-30	=	±0.4	
30-120	=	±0.6	
120-315	=	±1	
315-1000	=	±1.6	
1000-2000	=	±2.4	

PART NO.	
APPROVED	DATE 08-15-98'
CHECKED	DATE 08-15-98'
DRAWN	DATE 08-15-98'

KAI JACK INDUSTRIAL CO., LTD. TAINAN TAIWAN R.O.C.	
TITLE	BNC BULKHEAD RECEPT. JACK
DRAWING NO.	KJ-B6351D1-NDT-50
FILE NO.	F:\DWG\B\6351D1\NDT-50

F
E
D
C
B
A

F
E
D
C
B
A

1 2 3 4 5 6 7 8 8B-R4976