

REVISIONS			
ISS	ZONE	DESCRIPTION\PER REQUEST\DATE	

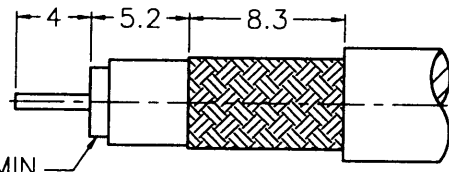

REMOVE FOIL 1mm MIN.
(去除箔膜 1mm 以上)

RECOMMENDED
CABLE STRIPPING DIM'S
(建議剝線尺寸)

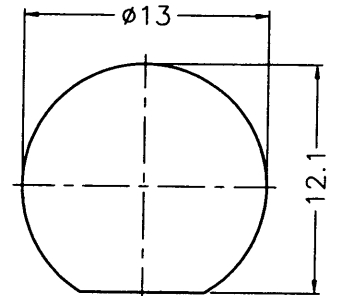

RECOMMENDED
MOUNTING HOLE
(建議架設孔)

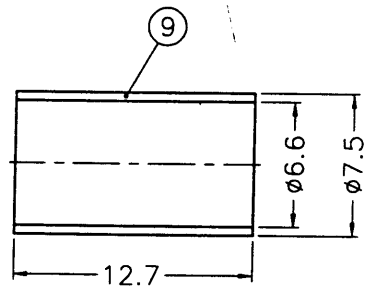
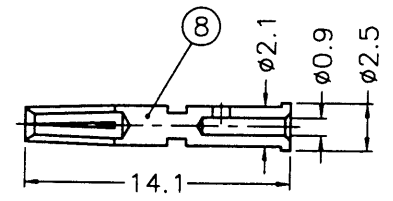
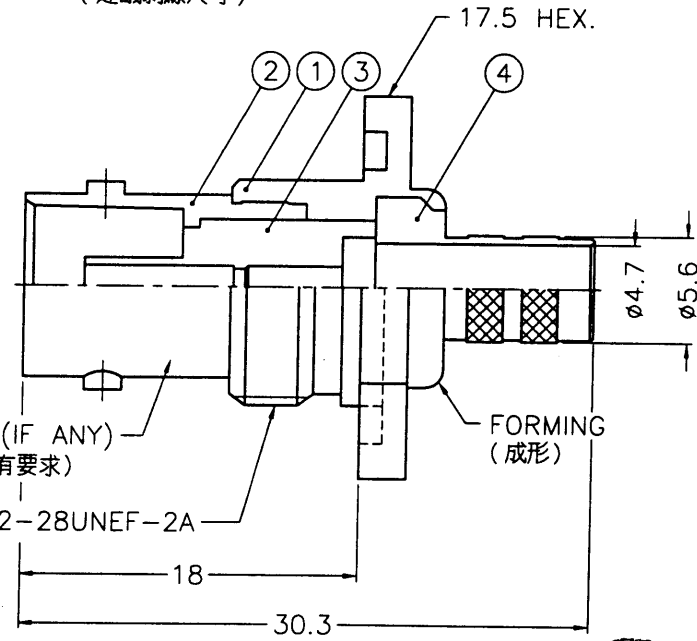
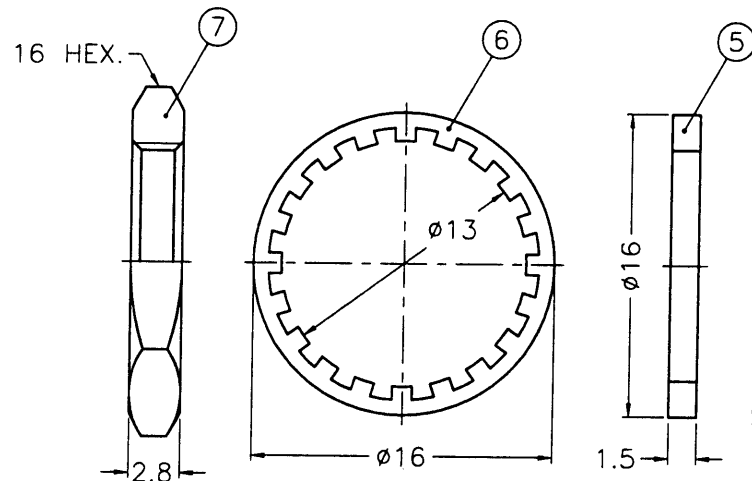

- NOTES: FINISH (PLATING THICKNESS IN MICRO-INCHES)
- BRASS PER QQ-B-626
 - BRASS PER QQ-B-613
 - NICKEL PL. 100 MIN. THICK OVER COPPER STRIKE
 - PHOSPHOR BRONZE PER QQ-B-750
 - GOLD PL. 3 MIN. THICK OVER NICKEL PL. 100 MIN. THICK OVER COPPER STRIKE
 - TEFLON MIL-P-19468
 - JIS H 3250, C 2600

- CRIMPED FERRULE
HEX CRIMP SIZE .255"
- CRIMPED CONTACT PIN
HEX CRIMP SIZE .068"
- MAX. PANEL THICKNESS=3.5mm



NO.	DESCRIPTION	MATERIAL	FINISH	Q'TY	DRAWING NO.
9	FERRULE			1	FR-75/66X127
8	CONTACT PIN			1	B74000-8-25/09
7	HEX NUT			1	HN16-1/2-28X28
6	LOCK WASHER			1	LW-16/13X05
5	GASKET	RUBBER	RED	1	GS-16/122X15
4	BARREL			1	BR00AAH18A
3	INSULATOR		NATURAL	1	B74000-3T-75T
2	BODY			1	B74000-2
1	HOUSING			1	B74000-1

DIMENSIONS ARE IN MILLIMETERS
UNLESS OTHERWISE SPECIFIED
TOLERANCES
0.5-6 = ±0.2
6-30 = ±0.4
30-120 = ±0.6
120-315 = ±1
315-1000 = ±1.6
1000-2000 = ±2.4

PART NO.	
APPROVED	DATE 12-16-02'
CHECKED	DATE 12-16-02'
DRAWN	DATE 12-16-02'

ANGELA

Amphenol	
Danbury,CT,USA-Tainan,Taiwan-Shenzhen,China	
TITLE BNC BULKHEAD CRIMP JACK	
DRAWING NO. B6421A1-011-NT3G-75T	
ITEM NO.	