

REVISIONS			
ISS	ZONE	DESCRIPTION\PER REQUEST\DATE	
B	B-3	NO.8 WAS CHANGED\RD-DM91082201W\08-22-02'	

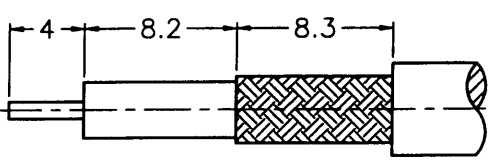

RECOMMENDED
CABLE STRIPPING DIM'S
(建議剝線尺寸)

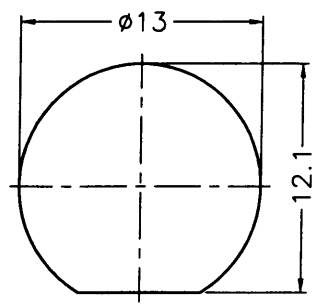

RECOMMENDED
MOUNTING HOLE
(建議架設孔)

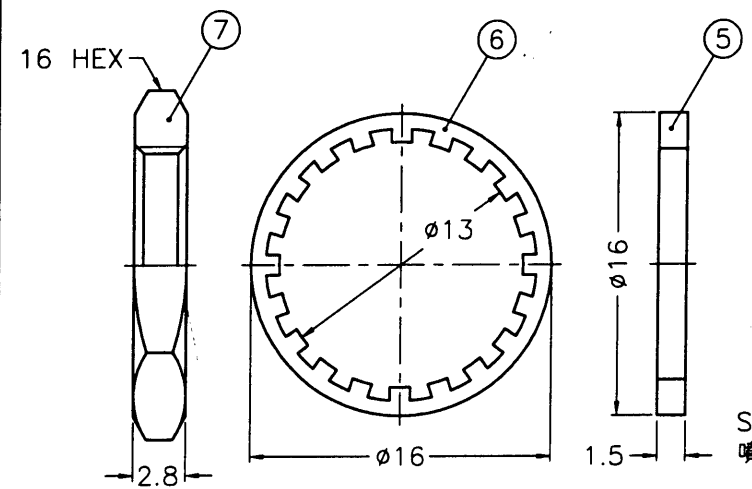

NOTES: FINISH (PLATING THICKNESS IN MICRO-INCHES)
 1. BRASS PER QQ-B-626
 2. BRASS PER QQ-B-613
 3. NICKEL PL. 100 MIN. THICK OVER COPPER STRIKE
 4. PHOSPHOR BRONZE PER QQ-B-750
 5. GOLD PL. 3 MIN. THICK OVER NICKEL PL. 100 MIN. THICK OVER COPPER STRIKE
 6. TEFLON MIL-P-19468
 7. JIS H 3250, C 2600

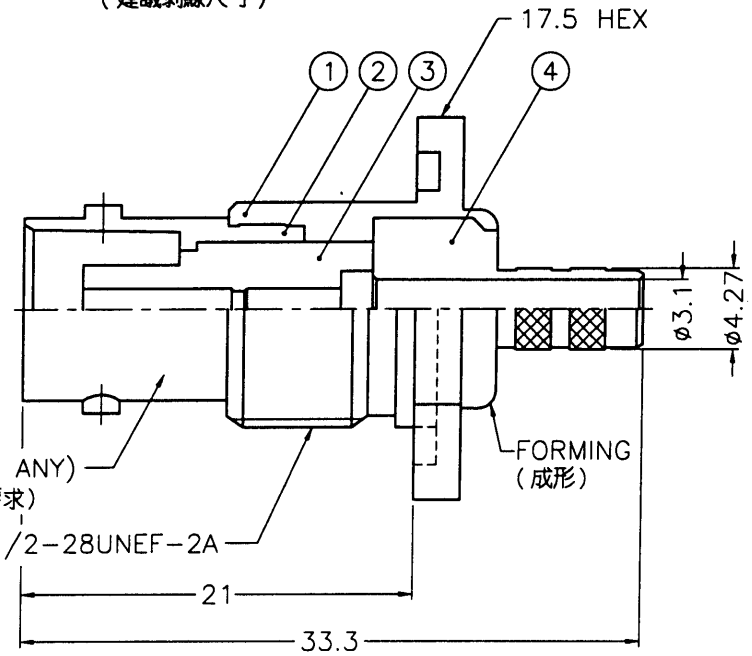

1. CRIMPED FERRULE
HEX CRIMP SIZE .213"
2. CRIMPED CONTACT PIN
HEX CRIMP SIZE .068"
3. MAX. PANEL THICKNESS=6.5mm

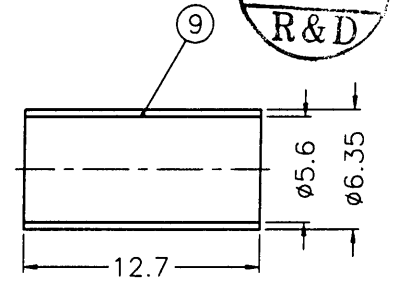
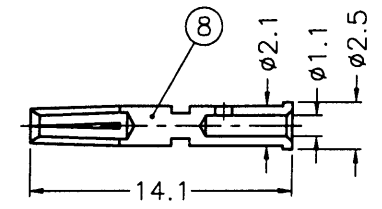

9	FERRULE	NOTE 7	NOTE 3	1	FR-635/56X127
8	CONTACT PIN	NOTE 4	NOTE 5	1	B74000-8-25/11
7	HEX NUT	NOTE 1	NOTE 3	1	HN16-1/2-28X28
6	LOCK WASHER	NOTE 2	NOTE 3	1	LW-16/13X05
5	GASKET	RUBBER	RED	1	GS-16/122X15
4	BARREL	NOTE 1	NOTE 3	1	B74010-4-427/31
3	INSULATOR	NOTE 6	NATURAL	1	B74000-3T-50
2	BODY	NOTE 1	NOTE 3	1	B74000-2
1	HOUSING	NOTE 1	NOTE 3	1	B74010-1
NO.	DESCRIPTION	MATERIAL	FINISH	Q'TY	DRAWING NO.

DIMENSIONS ARE IN MILLIMETERS				PART NO.	
UNLESS OTHERWISE SPECIFIED TOLERANCES				APPROVED	DATE
0.5-6	= ±0.2			<i>Angela W.</i>	08-22-02'
6-30	= ±0.4			CHECKED	DATE
30-120	= ±0.6			<i>Karl J.</i>	08-22-02'
120-315	= ±1			DRAWN	DATE
315-1000	= ±1.6			<i>Angela W.</i>	08-22-02'
1000-2000	= ±2.4			FILE NO.	F:\DWG\B\6421A2\223U-50\NT3G

Amphenol - Kai Jack	
TAINAN TAIWAN	
TITLE	BNC BULKHEAD CRIMP JACK (FOR RG-55/U, 142A/U, 400/U, 223/U)
DRAWING NO.	KJ-B6421A2-NT3G-223U-50
ITEM NO.	016421AAB26NA5F

F
E
D
C
B
A

F
E
D
C
B
A