

REVISIONS		
ISS	ZONE	DESCRIPTION \ APPROVED \ DATE

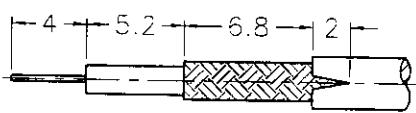

RECOMMENDED CABLE STRIPPING DIM'S

業務部

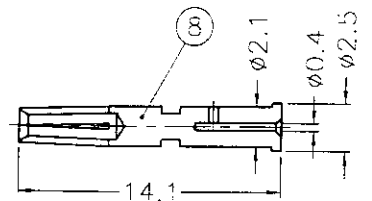
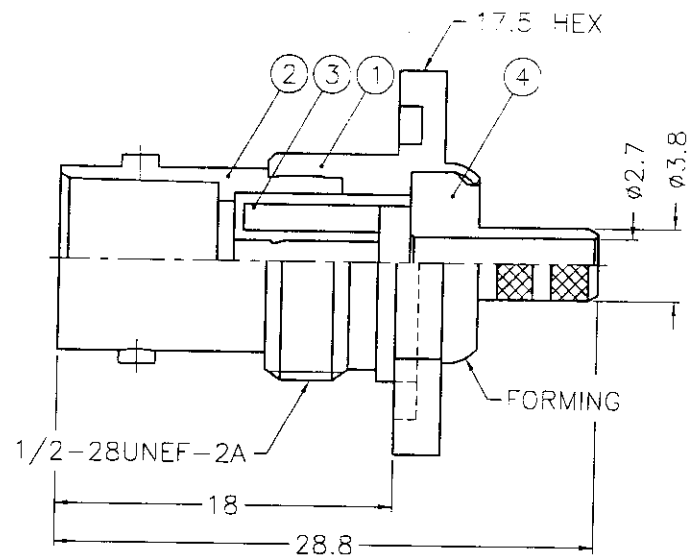
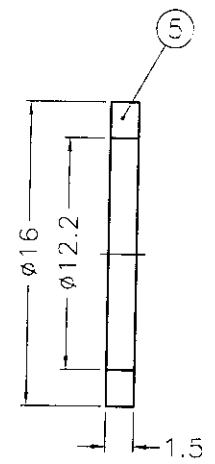
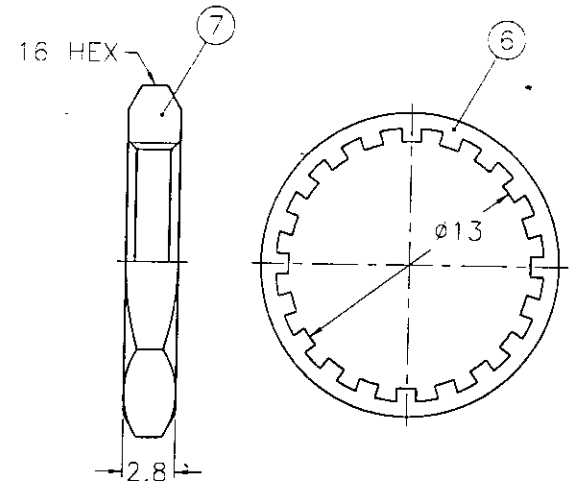

出圖  
87.8.11  
R&D

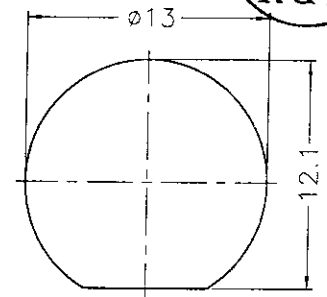

RECOMMENDED MOUNTING HOLE

- NOTES: FINISH (PLATING THICKNESS IN MICRO-INCHES)
1. BRASS PER QQ-B-626
  2. BRASS PER QQ-B-613
  3. NICKEL PL. 100 MIN. THICK OVER COPPER STRIKE
  4. PHOSPHOR BRONZE PER QQ-B-750
  5. GOLD PL. 3 MIN. THICK OVER NICKEL PL. 100 MIN. THICK OVER COPPER STRIKE
  6. JIS H 3260, C 3501

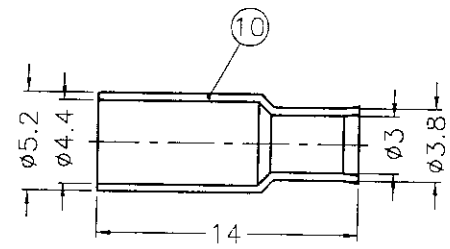
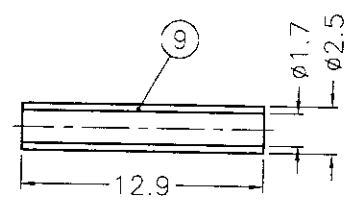

NO.	DESCRIPTION	MATERIAL	FINISH	Q'TY	DRAWING NO.
10	FERRULE	NOTE 5	NOTE 3	1	FR-52/44-38/3X14
9	SLEEVE	DELIN	NATURAL	1	SL-25/17X129
8	CONTACT PIN	NOTE 4	NOTE 5	1	B74000-8-25/04
7	HEX NUT	NOTE 1	NOTE 3	1	HN16-1/2-28X28
6	LOCK WASHER	NOTE 2	NOTE 3	1	LW-16/13X05
5	GASKET	RUBBER	RED	1	GS-16/122X15
4	BARREL	NOTE 1	NOTE 3	1	B74000-4-38/27S
3	INSULATOR	DELIN	NATURAL	1	B74050-3-75-B
2	BODY	NOTE 1	NOTE 3	1	B74000-2
1	HOUSING	NOTE 1	NOTE 3	1	B74000-1

DIMENSIONS ARE IN MILLIMETERS		PART NO.	
UNLESS OTHERWISE SPECIFIED TOLERANCES		APPROVED	
0.5-6 = ±0.2		DATE 08-07-98'	
6-30 = ±0.4		CHECKED	
30-120 = ±0.6		DATE 08-07-98'	
120-315 = ±1		DRAWN	
315-1000 = ±1.6		DATE 08-07-98'	
1000-2000 = ±2.4		SCALE 2.5/1 ISSUE A	

**KAI JACK INDUSTRIAL CO., LTD.**  
TAINAN TAIWAN R.O.C.

TITLE: BNC BULKHEAD CRIMP JACK (FOR RG-179/U, 187A/U)  
DRAWING NO.: KJ-B6421E1-ND3G-179U-75  
FILE NO.: F:\DWG\B\6421E1\179U-75\ND3G

Mark C  
Mark C  
Betty S.