

業務部

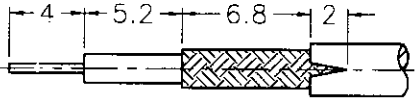

RECOMMENDED CABLE STRIPPING DIM'S

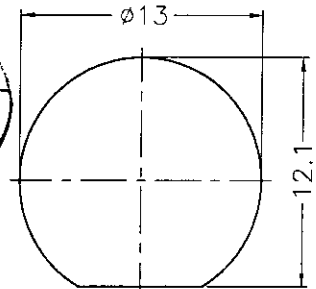
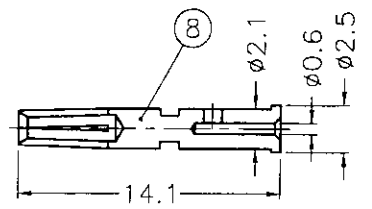
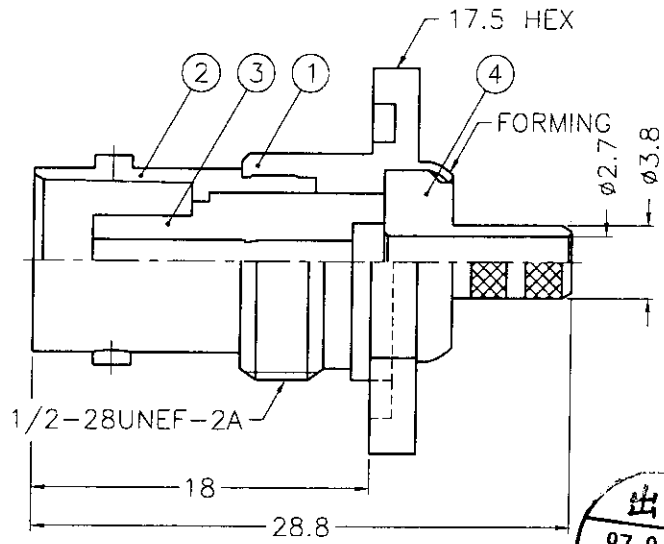
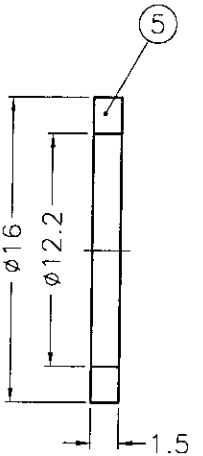
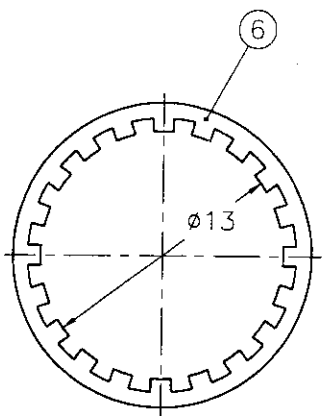
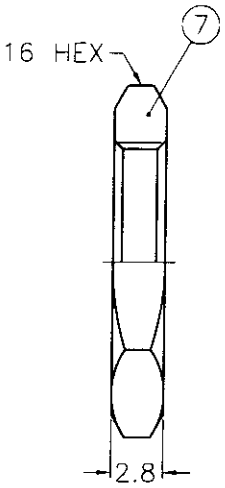

RECOMMENDED MOUNTING HOLE

出圖  
87.8.17  
R&D

- NOTES: FINISH (PLATING THICKNESS IN MICRO-INCHES)
1. BRASS PER QQ-B-626
  2. BRASS PER QQ-B-613
  3. NICKEL PL. 100 MIN. THICK OVER COPPER STRIKE
  4. PHOSPHOR BRONZE PER QQ-B-750
  5. GOLD PL. 3 MIN. THICK OVER NICKEL PL. 100 MIN. THICK OVER COPPER STRIKE
  6. JIS H 3260, C 3501

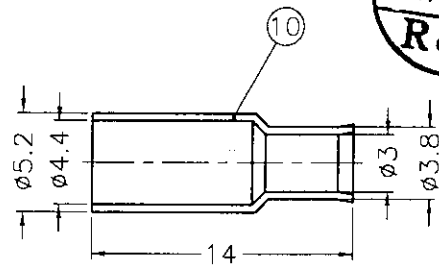
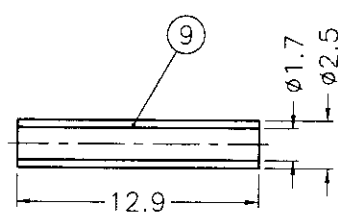

10	FERRULE	NOTE 6	NOTE 3	1	FR-52/44-38/3 X14
9	SLEEVE	DELIN	NATURAL	1	SL-25/17X129
8	CONTACT PIN	NOTE 4	NOTE 5	1	B74000-8-25/06
7	HEX NUT	NOTE 1	NOTE 3	1	HN16-1/2-28X28
6	LOCK WASHER	NOTE 2	NOTE 3	1	LW-16/13X05
5	GASKET	RUBBER	RED	1	GS-16/122X15
4	BARREL	NOTE 1	NOTE 3	1	B74000-4-38/27S
3	INSULATOR	DELIN	NATURAL	1	B74050-3-50-B
2	BODY	NOTE 1	NOTE 3	1	B74000-2
1	HOUSING	NOTE 1	NOTE 3	1	B74000-1

DIMENSIONS ARE IN MILLIMETERS		PART NO.	
UNLESS OTHERWISE SPECIFIED TOLERANCES		APPROVED	DATE
0.5-6 = ±0.2		<i>Mark C</i>	08-15-98'
6-30 = ±0.4		CHECKED	DATE
30-120 = ±0.6		<i>Mark C</i>	08-15-98'
120-315 = ±1		DRAWN	DATE
315-1000 = ±1.6		<i>Betty L.</i>	08-15-98'
1000-2000 = ±2.4			
SCALE 2.5/1	ISSUE A		

<p>KAI JACK INDUSTRIAL CO., LTD. TAINAN TAIWAN R.O.C.</p>	
TITLE	BNC BULKHEAD CRIMP JACK (FOR RG-174/U,188A/U,316/U)
DRAWING NO.	KJ-B6421E1-ND3G-316U-50
FILE NO.	F:\DWG\B\6421E1\316U-50\ND3G

8B-R494