

ISS	ZONE	DESCRIPTION \ PER REQUEST \ DATE
A1	D-5	NO.3 WAS CHANGED \ N \ A \ 06-10-02'

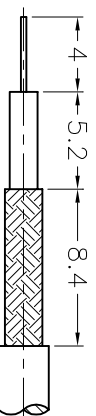

1. CRIMPED FERRULE HEX. CRIMP SIZE .178"
2. CRIMPED CONTACT PIN HEX. CRIMP SIZE .068"
3. MAX. PANEL THICKNESS=3.5mm

RECOMMENDED CABLE STRIPPING DIM'S
(建議剝線尺寸)

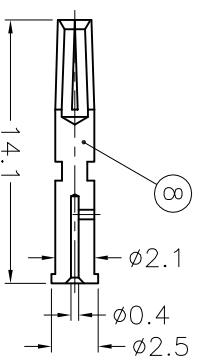
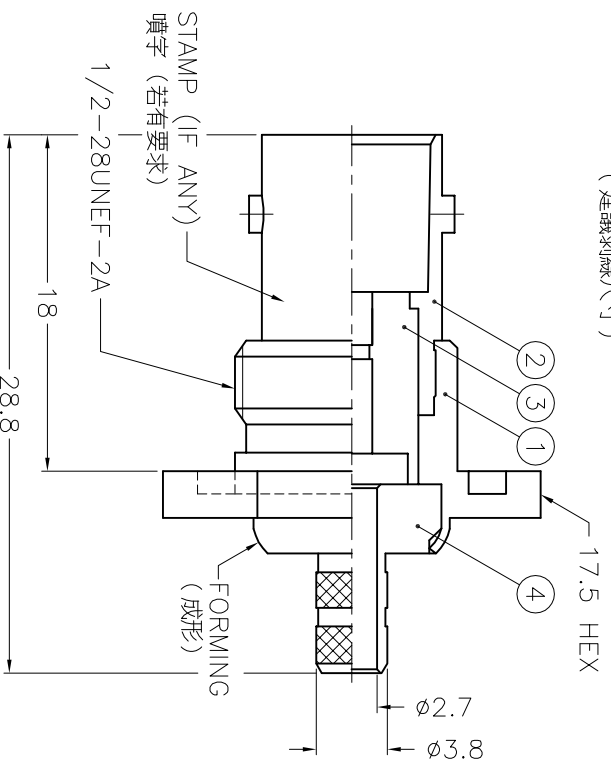
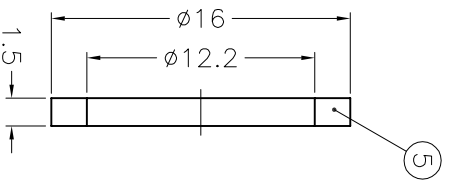
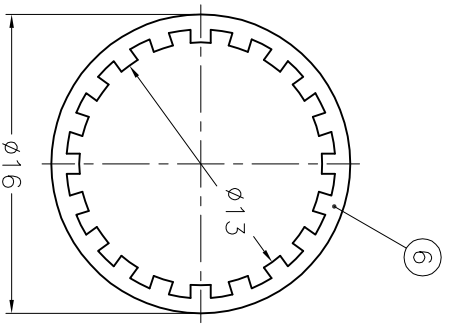
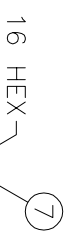

- NOTES: FINISH (PLATING THICKNESS IN MICRO-INCHES)
1. BRASS PER 00-B-626
 2. BRASS PER 00-B-613
 3. NICKEL PL. 100 MIN. THICK OVER COPPER STRIKE
 4. PHOSPHOR BRONZE PER 00-B-750
 5. GOLD PL. 3 MIN. THICK OVER NICKEL PL. 100 MIN. THICK OVER COPPER STRIKE
 6. TEFLON MIL-P-19468

NO.	DESCRIPTION	MATERIAL	FINISH	Q'TY	DRAWING NO.
10	FERRULE	NOTE 1	NOTE 3	1	FR-52/44-38/3X
9	SLEEVE	DELRIN	NATURAL	14	
8	CONTACT PIN	NOTE 4	NOTE 5	1	SL-25/17X129
7	HEX NUT	NOTE 1	NOTE 3	1	B74000-8-25/04
6	LOCK WASHER	NOTE 2	NOTE 3	1	HN16-1/2-28X28
5	GASKET	RUBBER	RED	1	LW-16/13X05
4	BARREL	NOTE 1	NOTE 3	1	GS-16/122X15
3	INSULATOR	NOTE 6	NATURAL	1	B74000-4-38/27S
2	BODY	NOTE 1	NOTE 3	1	B74000-3T-75
1	HOUSING	NOTE 1	NOTE 3	1	B74000-2
				1	B74000-1

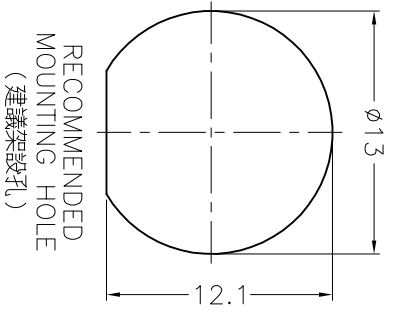
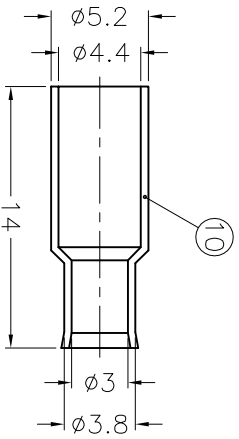
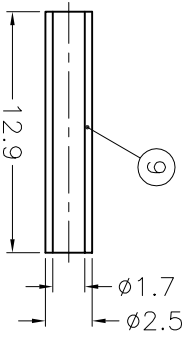

Amphenol - Kai Jack

TAINAN TAIWAN

BNC BULKHEAD CRIMP JACK
(FOR RG-179/U, 187A/U CABLE)

DIMENSIONS ARE IN MILLIMETERS		PART NO.	
UNLESS OTHERWISE SPECIFIED	TOLERANCES	APPROVED	DATE
0.5-6 = ±0.2	6-30 = ±0.4	CHECKED	DATE
30-120 = ±0.6	120-315 = ±1	DRAWN	DATE
315-1000 = ±1.6	1000-2000 = ±2.4		

SCALE: 2.5/1		ISSUE: A1	
FILE NO.	F:\DWG\B\6421E1\179U-75\NT3G	FILE NO.	F:\DWG\B\6421E1\179U-75\NT3G
ITEM NO.	016421AAD19NA7F	ITEM NO.	016421AAD19NA7F
DRAWING NO.	KJ-B6421E1-NT3G-179U-75	DRAWING NO.	KJ-B6421E1-NT3G-179U-75