

REVISIONS		
ISS	ZONE	DESCRIPTION\PER REQUEST\DATE

**SALES**

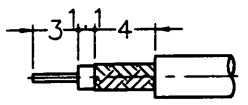

RECOMMENDED  
CABLE STRIPPING DIM'S  
(建議剝線尺寸)

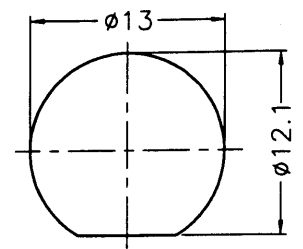

RECOMMENDED  
MOUNTING HOLE  
(建議架設孔)

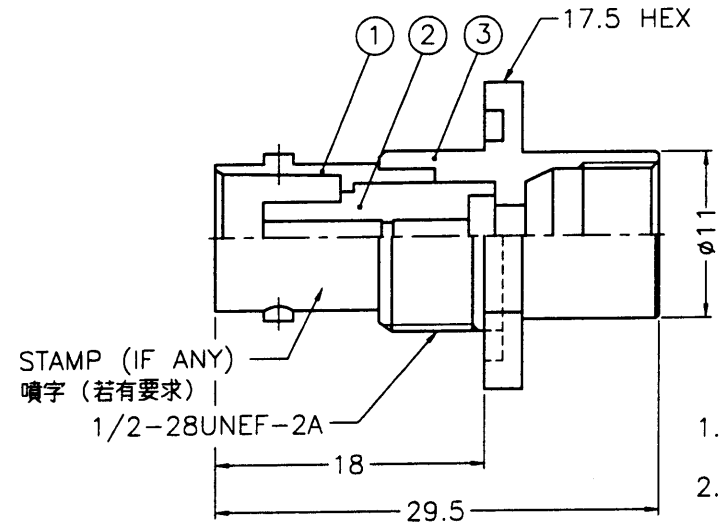
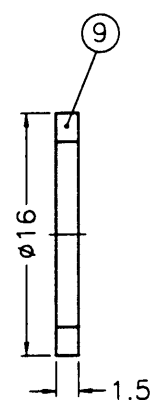
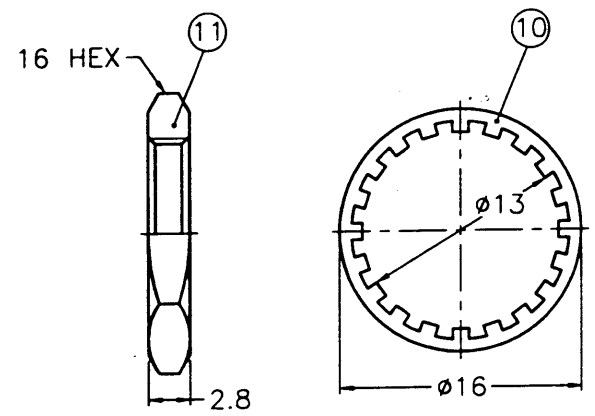

ISSUED  
2002. 9. 24  
M & D

1. CRIMPED CONTACT PIN  
HEX CRIMP SIZE .068"
2. MAX. PANEL THICKNESS=3.5mm

NOTES: FINISH (PLATING THICKNESS IN MICRO-INCHES)  
 1. BRASS PER QQ-B-626  
 2. BRASS PER QQ-B-613  
 3. NICKEL PL. 100 MIN. THICK OVER COPPER STRIKE  
 4. PHOSPHOR BRONZE PER QQ-B-750  
 5. GOLD PL. 3 MIN. THICK OVER NICKEL PL. 100 MIN. THICK OVER COPPER STRIKE  
 6. TEFLON MIL-P-19468

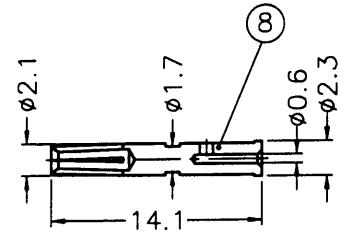
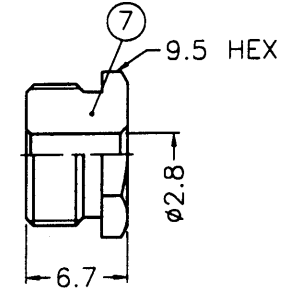
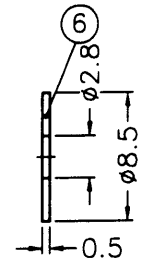
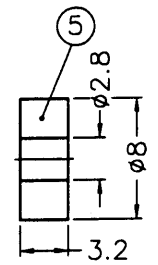
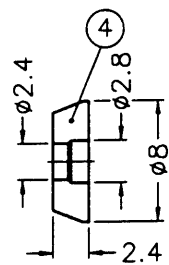

11	HEX NUT	NOTE 1	NOTE 3	1	HN16-1/2-28X28
10	WASHER	NOTE 2	NOTE 3	1	LW-16/13X05
9	GASKET	RUBBER	RED	1	GS-16/122X15
8	CONTACT PIN	NOTE 4	NOTE 5	1	B74000-8-23/06
7	HEX NUT	NOTE 1	NOTE 3	1	B5205-12-95/28
6	WASHER	NOTE 2	NOTE 3	1	WS-85/28X05
5	GASKET	SILICONE	RED	1	GS-8/28X32
4	TOP HAT	NOTE 1	NOTE 3	1	B5205-9-28/24-B
3	HOUSING	NOTE 1	NOTE 3	1	HS00AKZ01A
2	INSULATOR	NOTE 6	NATURAL	1	B74000-3T-50
1	BODY	NOTE 1	NOTE 3	1	B74000-2

DIMENSIONS ARE IN MILLIMETERS  
 UNLESS OTHERWISE SPECIFIED  
 TOLERANCES  
 0.5-6 = ±0.2  
 6-30 = ±0.4  
 30-120 = ±0.6  
 120-315 = ±1  
 315-1000 = ±1.6  
 1000-2000 = ±2.4

PART NO.	
APPROVED	DATE 09-23-02'
CHECKED	DATE 09-23-02'
DRAWN	DATE 09-23-02'
FILE NO.	F:\DWG\B\6441C1\316U-50\NT3G

Amphenol - Kai Jack	
TAINAN TAIWAN	
TITLE	BNC BULKHEAD CLAMP JACK (FOR RG-174/U, 188A/U, 316/U)
DRAWING NO.	KJ-B6441C1-NT3G-316U-50
ITEM NO.	016441AAA36NA5F

7RD-DR15559 8