

1 2 3 4 5 6 7 8

REVISIONS		
ISS	ZONE	DESCRIPTION\APPROVED\DATE

業務部

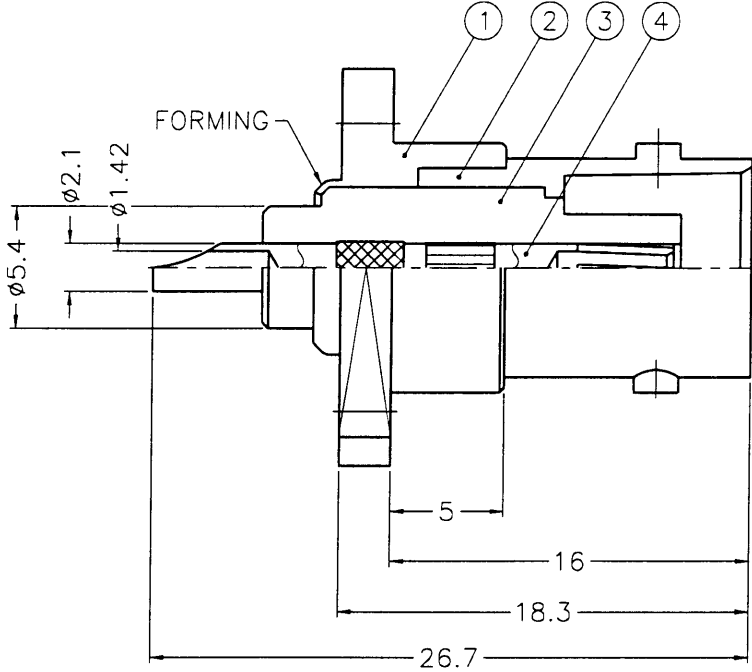
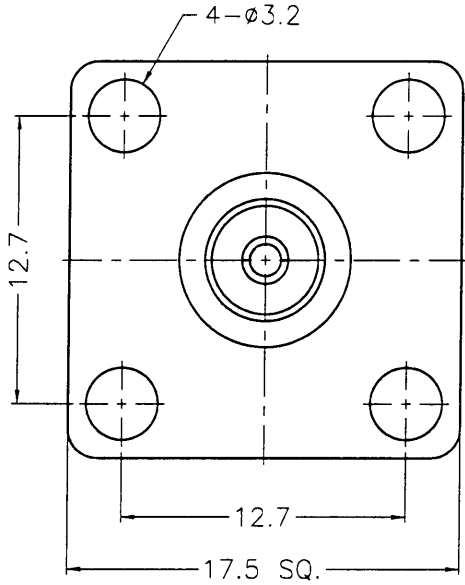

- NOTES: FINISH (PLATING THICKNESS IN MICRO-INCHES)
- BRASS PER QQ-B-626
  - NICKEL PL. 100 MIN. THICK OVER COPPER STRIKE
  - PHOSPHOR BRONZE PER QQ-B-750
  - GOLD PL. 3 MIN. THICK OVER NICKEL PL. 100 MIN. THICK OVER COPPER STRIKE
  - TEFLON MIL-P-19468

出圖  
87.11.11  
R&D

DIMENSIONS ARE IN MILLIMETERS			
UNLESS OTHERWISE SPECIFIED TOLERANCES			
0.5-6	=	±0.2	
6-30	=	±0.4	
30-120	=	±0.6	
120-315	=	±1	
315-1000	=	±1.6	
1000-2000	=	±2.4	

PART NO.	
APPROVED	<i>Joan J. C.</i> DATE 11-09-98'
CHECKED	<i>Case. W</i> DATE 11-09-98'
DRAWN	<i>Betty S</i> DATE 11-09-98'

	<b>KAI JACK INDUSTRIAL CO., LTD.</b> TAINAN TAIWAN R.O.C.
TITLE	BNC PANEL JACK
DRAWING NO.	KJ-B6551A1-NT3G-50
FILE NO.	F:\DWG\B\6551A1\50\NT3G

NO.	DESCRIPTION	MATERIAL	FINISH	Q'TY	DRAWING NO.
4	CONTACT PIN	NOTE 3	NOTE 4	1	B7310-3-50
3	INSULATOR	NOTE 5	NATURAL	1	B75300-3T-50-E
2	BODY	NOTE 1	NOTE 2	1	B74000-2
1	HOUSING	NOTE 1	NOTE 2	1	B75300-1

A

A

1 2 3 4 5 6 7 8 88-R5060