

REVISIONS		
ISS	ZONE	DESCRIPTION\PER REQUEST\DATE
B	A-1	NO.1, 2, 3 AND 4 WERE CHANGED\RD-DM88051901C \05-19-99'

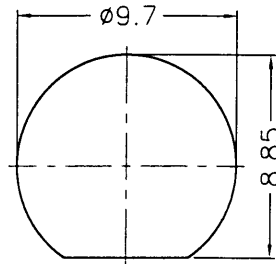

RECOMMENDED MOUNTING HOLE
(建議架設孔)

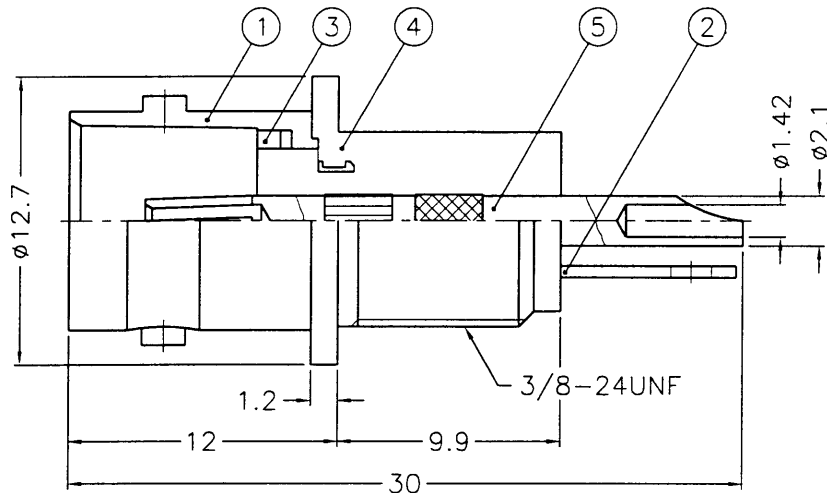
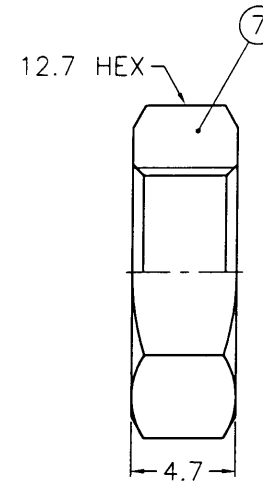
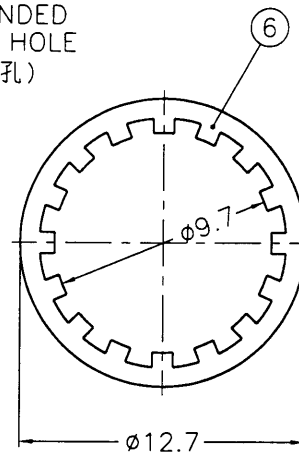

NOTES: FINISH (PLATING THICKNESS IN MICRO-INCHES)

- BRASS PER QQ-B-626
- BRASS PER QQ-B-613
- NICKEL PL. 100 MIN. THICK OVER COPPER STRIKE
- PHOSPHOR BRONZE PER QQ-B-750
- GOLD PL. 3 MIN. THICK OVER NICKEL PL. 100 MIN. THICK OVER COPPER STRIKE
- BRIGHT TIN PL. 200 MIN. THICK OVER NICKEL PL. 50 MIN. THICK OVER COPPER PL. 100 MIN. THICK

RECOMMENDED TORQUE: A MAXIMUM TORQUE OF 12 INCH-LBS MAY BE APPLIED ON HEX NUT WHEN MOUNTING CONNECTOR IN PANEL.
(建議扭力:當架設接頭於基板時 六角螺母最大適用12 inch-lbs 的扭力)

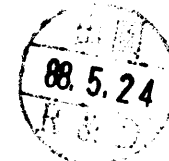

NO.	DESCRIPTION	MATERIAL	FINISH	Q'TY	DRAWING NO.
7	HEX NUT			1	HN127-3/8-24X47
6	LOCK WASHER			1	LW-127/97X05
5	CONTACT PIN			1	B7300-5
4	INSULATOR	NYLON	WHITE	1	B6651B1-1-75-
3	LOCK RING			1	C
2	BRAID GROUNDING			1	
1	BODY			1	

DIMENSIONS ARE IN MILLIMETERS
UNLESS OTHERWISE SPECIFIED TOLERANCES
0.5-6 = ±0.2
6-30 = ±0.4
30-120 = ±0.6
120-315 = ±1
315-1000 = ±1.6
1000-2000 = ±2.4

PART NO.	
APPROVED	DATE 05-20-99'
CHECKED	DATE 05-20-99'
DRAWN	DATE 05-20-99'



KAI JACK INDUSTRIAL CO., LTD.
TAINAN TAIWAN R.O.C.

TITLE
BNC BULKHEAD RECEPT. ISOLATED JACK
DRAWING NO.
KJ-B6651B1-NNYL3G-75
FILE NO.
F:\DWG\B\6651B1\75\NNYL3G

A