

REVISIONS		
ISS	ZONE	DESCRIPTION\PER REQUEST\DATE

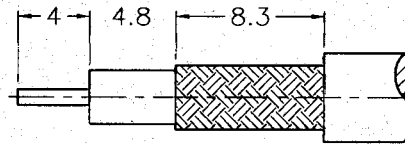

RECOMMENDED
CABLE STRIPPING DIM'S
(«OA3-e½u?O?o

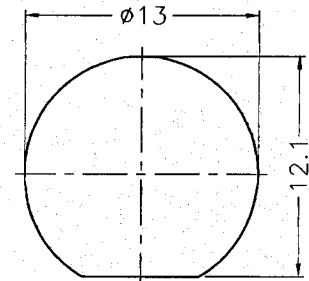

RECOMMENDED
MOUNTING HOLE
(«OA3?[3]?O

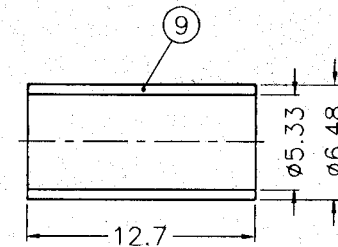
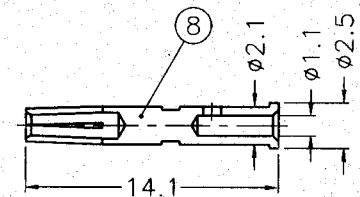
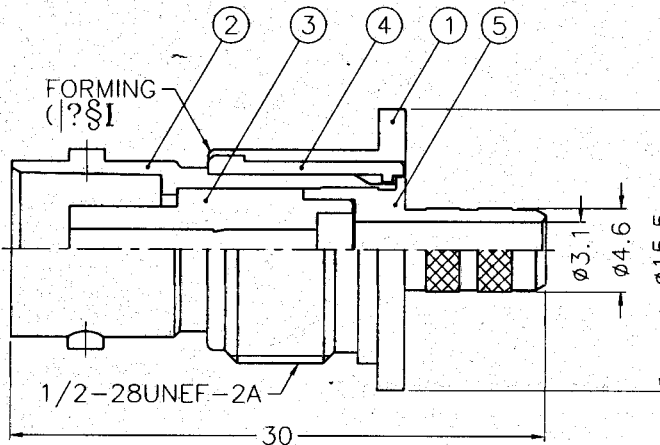
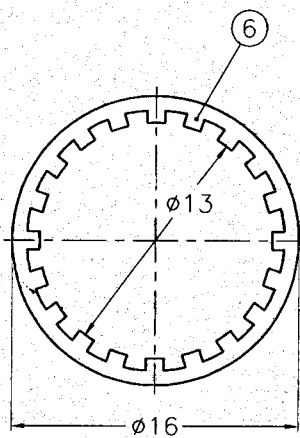
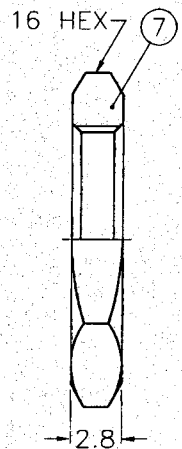

NOTES: FINISH (PLATING THICKNESS IN MICRO-INCHES)

1. BRASS PER QQ-B-626
2. BRASS PER QQ-B-613
3. NICKEL PL. 100 MIN. THICK OVER COPPER STRIKE
4. PHOSPHOR BRONZE PER QQ-B-750
5. GOLD PL. 3 MIN. THICK OVER NICKEL PL. 100 MIN. THICK OVER COPPER STRIKE

THIS DRAWING HAS APPROVED BY:

CUSTOMER SIGNATURE
DATE: _____

1. CRIMPED FERRULE
HEX CRIMP SIZE .213"
2. CRIMPED CONTACT PIN
HEX CRIMP SIZE .068"

9	FERRULE	COPPER	NOTE 3	1	FR-64B/533X 127C
8	CONTACT PIN	NOTE 4	NOTE 5	1	B74000-8-25/11
7	HEX NUT	NOTE 1	NOTE 3	1	HN16-1/2-28X28
6	LOCK WASHER	NOTE 2	NOTE 3	1	LW-16/13X05
5	BARREL	NOTE 1	NOTE 3	1	B74040-5-46/31
4	INSULATOR	DELRI	NATURAL	1	B74040-4
3	INSULATOR	DELRI	NATURAL	1	B74090-3-50-B
2	BODY	NOTE 1	NOTE 3	1	B74040-2
1	HOUSING	NOTE 1	NOTE 3	1	B74040-1
NO.	DESCRIPTION	MATERIAL	FINISH	Q'TY	DRAWING NO.

DIMENSIONS ARE IN MILLIMETERS

UNLESS OTHERWISE SPECIFIED TOLERANCES

- 0.5-6 = ±0.2
- 6-30 = ±0.4
- 30-120 = ±0.6
- 120-315 = ±1
- 315-1000 = ±1.6
- 1000-2000 = ±2.4

PART NO.

APPROVED

DATE

11-19-98'

CHECKED

DATE

11-19-98'

DRAWN

DATE

11-19-98'

Amphenol - Kai Jack

TAINAN TAIWAN

TITLE

BNC BULKHEAD CRIMP JACK
ISOLATED GROUND

DRAWING NO.

KJ-B6721B1-ND3G-58CU-50

FILE NO.

F:\DWG\B\6721B1\58CU-50\ND3G