

REVISIONS		
ISS	ZONE	DESCRIPTION\APPROVED\DATE

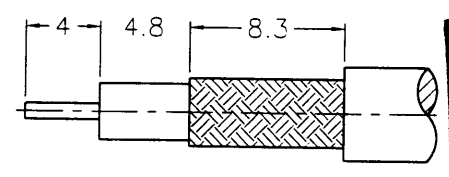

業務部

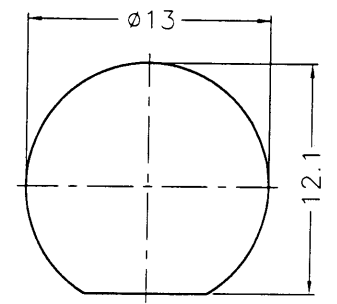

RECOMMENDED CABLE STRIPPING DIM'S

RECOMMENDED MOUNTING HOLE

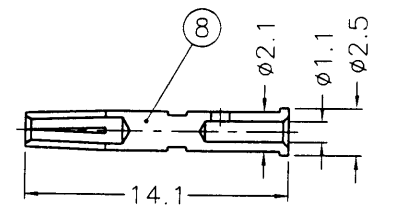
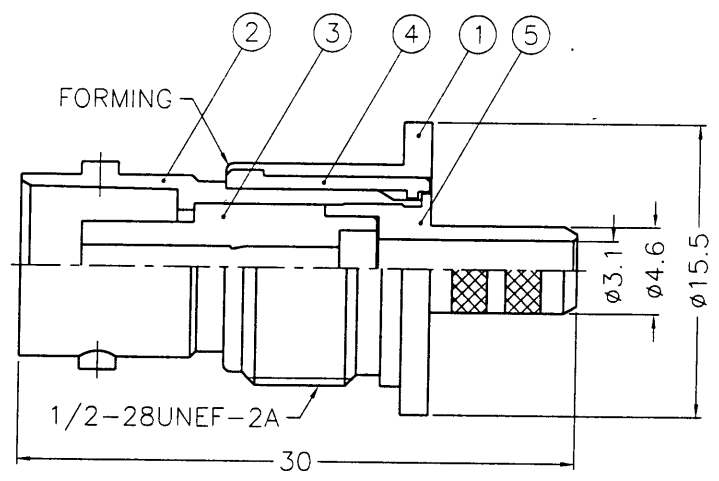
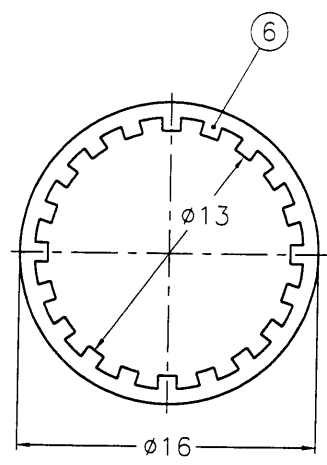
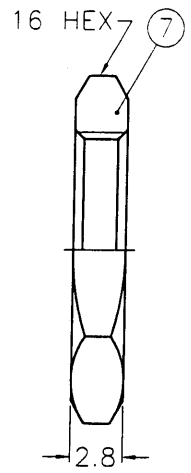

NOTES: FINISH (PLATING THICKNESS IN MICRO-INCHES)
 1. BRASS PER QQ-B-626
 2. BRASS PER QQ-B-613
 3. NICKEL PL. 100 MIN. THICK OVER COPPER STRIKE
 4. PHOSPHOR BRONZE PER QQ-B-750
 5. GOLD PL. 3 MIN. THICK OVER NICKEL PL. 100 MIN. THICK OVER COPPER STRIKE

出圖
87.11.24
R & D

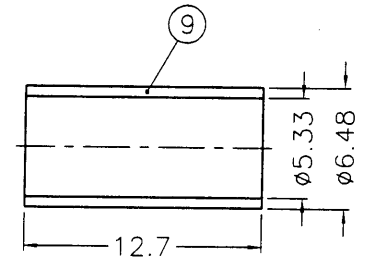

NO.	DESCRIPTION	MATERIAL	FINISH	Q'TY	DRAWING NO.
9	FERRULE	COPPER	NOTE 3	1	FR-648/533X 127C
8	CONTACT PIN	NOTE 4	NOTE 5	1	B74000-8-25/11
7	HEX NUT	NOTE 1	NOTE 3	1	HN16-1/2-28X28
6	LOCK WASHER	NOTE 2	NOTE 3	1	LW-16/13X05
5	BARREL	NOTE 1	NOTE 3	1	B74040-5-46/31
4	INSULATOR	DELTRIN	NATURAL	1	B74040-4
3	INSULATOR	DELTRIN	NATURAL	1	B74090-3-50-B
2	BODY	NOTE 1	NOTE 3	1	B74040-2
1	HOUSING	NOTE 1	NOTE 3	1	B74040-1

DIMENSIONS ARE IN MILLIMETERS			PART NO.		
UNLESS OTHERWISE SPECIFIED TOLERANCES			APPROVED	DATE	
0.5-6	= ±0.2	SCALE 2.5/1	Mark.C	11-19-98'	
6-30	= ±0.4			CHECKED	DATE
30-120	= ±0.6			Mark.C	11-19-98'
120-315	= ±1			DRAWN	DATE
315-1000	= ±1.6			Betty S	11-19-98'
1000-2000	= ±2.4	ISSUE	A		

KAI JACK INDUSTRIAL CO., LTD.
TAINAN TAIWAN R.O.C.

TITLE: BNC BULKHEAD CRIMP JACK ISOLATED GROUND

DRAWING NO.: KJ-B6721B1-ND3G-58CU-50

FILE NO.: F:\DWG\B\6721B1\58CU-50\ND3G

F
E
D
C
B
A