

1		2		3		4		5		6		7		8	
ISS	ZONE	DESCRIPTION \ PER REQUEST \ DATE													
A1	-	DIMENSIONS WAS CHANGED \ N/A \ 07-18-01'													
A2	B-1	ADDED NO.9 & NO.10 \ N/A \ 01-18-02'													

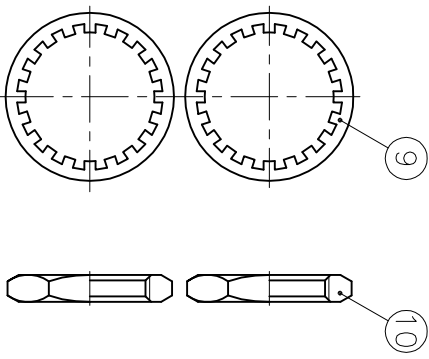
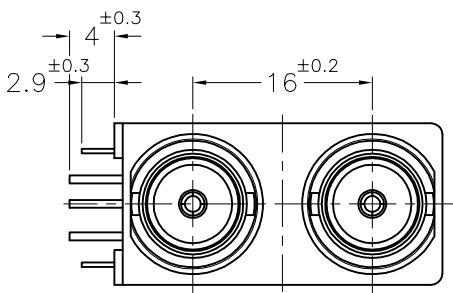
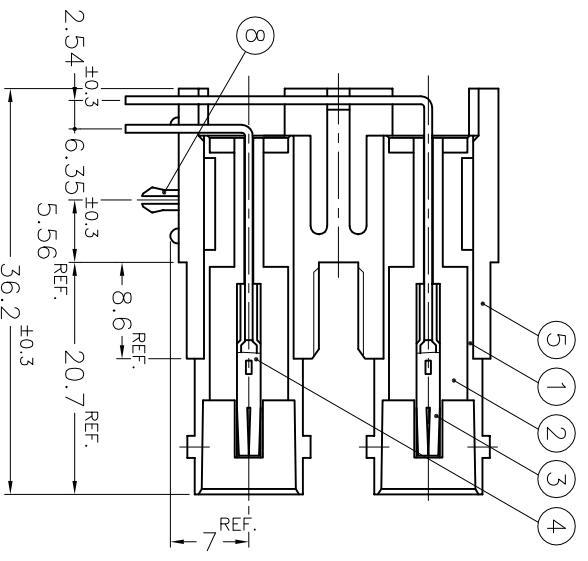
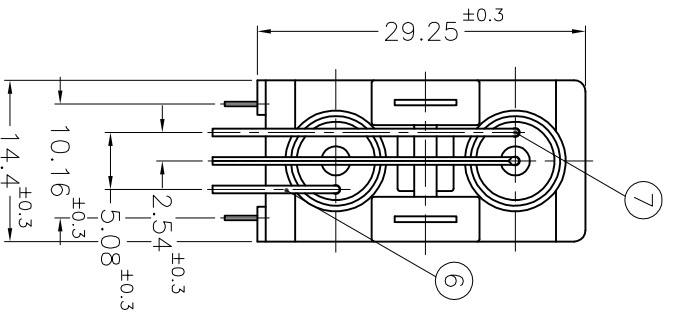

NOTES: FINISH (PLATING THICKNESS IN MICRO-INCHES)

1. BRASS PER QQ-B-626
2. ZINC DIECAST
3. NICKEL PL. 100 MIN. THICK OVER COPPER STRIKE
4. PHOSPHOR BRONZE PER QQ-B-750
5. GOLD FLASH OVER NICKEL PL. 100 MIN. THICK OVER COPPER STRIKE AT MATING AREA.
6. BRIGHT TIN PL. 80 MIN. THICK OVER COPPER PL. 100 MIN. THICK
7. POLYPROPYLENE UL 94HB
8. PBT (UL 94 V-0)
9. NICKEL PL. 80 MIN. THICK OVER COPPER STRIKE
10. BRASS PER QQ-B-613

DIMENSIONS ARE IN MILLIMETERS

UNLESS OTHERWISE SPECIFIED TOLERANCES

- 0.5-6 = ±0.2
- 6-30 = ±0.4
- 30-120 = ±0.6
- 120-315 = ±1
- 315-1000 = ±1.6
- 1000-2000 = ±2.4

10	HEX NUT	NOTE 1	NOTE 9	2
9	LOCK WASHER	NOTE 10	NOTE 9	2
8	MOUNTING POST	NOTE 1	NOTE 6	2
7	POST	COPPER	NOTE 6	1
6	POST	COPPER	NOTE 6	1
5	HOUSING	NOTE 8	NATURAL	1
4	CONTACT PIN	NOTE 4	NOTE 5	1
3	CONTACT PIN	NOTE 4	NOTE 5	1
2	INSULATOR	NOTE 7	NATURAL	2
1	BODY	NOTE 2	NOTE 3	2

1	2	3	4	5	6	7	8
NO.	DESCRIPTION	MATERIAL	FINISH	Q'TY	DRAWING NO.	SCALE	1.5/1
						ISSUE	A2
						FILE NO.	F:\DWG\B\705000\75\NPB3G

PART NO.		DATE	
APPROVED		01-18-02'	
CHECKED		01-18-02'	
DRAWN		01-18-02'	

# Amphenol - Kai Jack

TAINAN TAIWAN  
DUAL PORT BNC R/A PCB  
MOUNT RECEPTACLE

DRAWING NO. KJ-B705000-NPB3G-75  
ITEM NO. 017050AAA00MA7F