

1 2 3 4 5 6 7 8

REVISIONS		
ISS	ZONE	DESCRIPTION \ PER REQUEST \ DATE

業務部

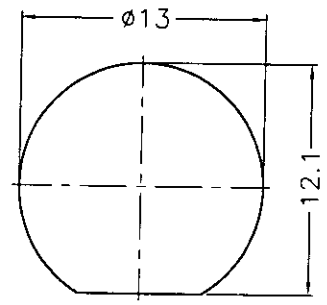
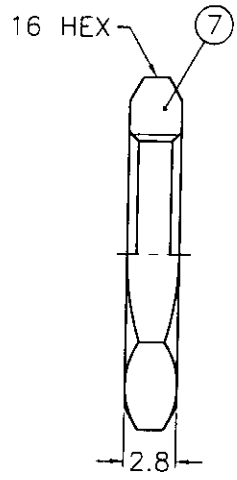
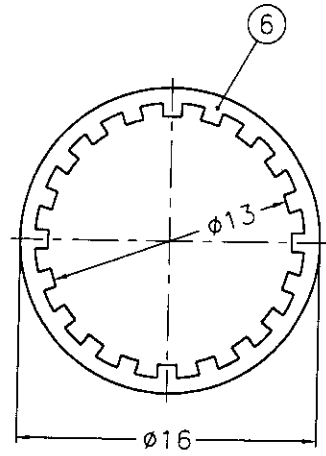
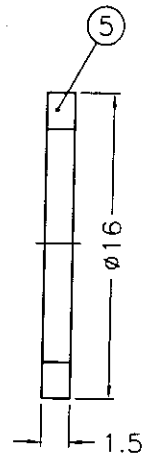
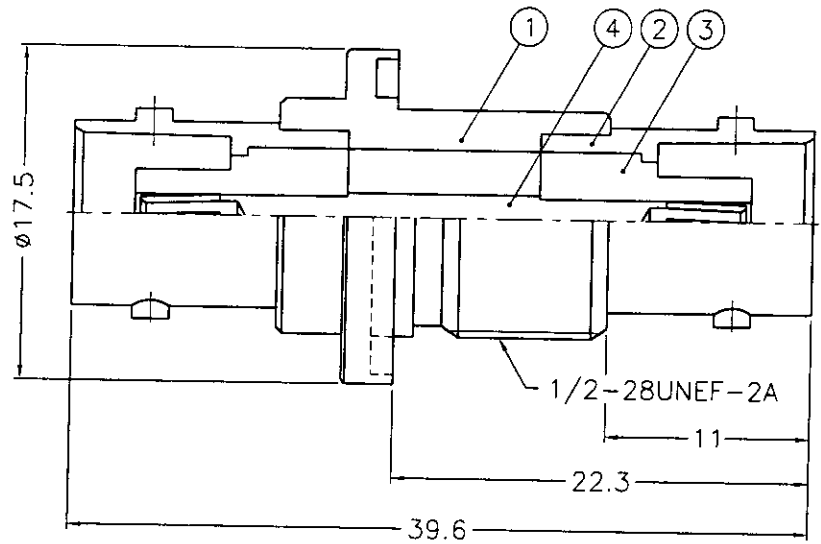

RECOMMENDED MOUNTING HOLE



NOTES: FINISH (PLATING THICKNESS IN MICRO-INCHES)
 1. BRASS PER QQ-B-626
 2. BRASS PER QQ-B-613
 3. NICKEL PL. 100 MIN. THICK OVER COPPER STRIKE
 4. PHOSPHOR BRONZE PER QQ-B-750
 5. GOLD PL. 30 MIN. THICK OVER NICKEL PL. 100 MIN. THICK OVER COPPER STRIKE

NO.	DESCRIPTION	MATERIAL	FINISH	Q'TY	DRAWING NO.
7	HEX NUT	NOTE 1	NOTE 3	1	HN16-1/2-28X2B
6	LOCK WASHER	NOTE 2	NOTE 3	1	LW-16/13X05
5	GASKET	RUBBER	RED	1	GS-16/122X15
4	CONTACT PIN	NOTE 4	NOTE 5	1	B7910-4
3	INSULATOR	DELIN	NATURAL	2	B7996ZZ-3-50
2	BODY	NOTE 1	NOTE 3	2	B74000-2
1	HOUSING	NOTE 1	NOTE 3	1	B7910-1

DIMENSIONS ARE IN MILLIMETERS
 UNLESS OTHERWISE SPECIFIED TOLERANCES
 0.5-6 = ±0.2
 6-30 = ±0.4
 30-120 = ±0.6
 120-315 = ±1
 315-1000 = ±1.6
 1000-2000 = ±2.4

PART NO.
 APPROVED *Mark C* DATE 04-26-99'
 CHECKED *Mark C* DATE 04-26-99'
 DRAWN *Betty S* DATE 04-26-99'

KAI JACK INDUSTRIAL CO., LTD.
 TAINAN TAIWAN R.O.C.
 TITLE
 BNC FEMALE TO FEMALE BULKHEAD ADAPTOR
 DRAWING NO.
 KJ-B7471A1-ND3G-50
 FILE NO. F:\DWG\B\7471A1\50\ND3G

F
E
D
C
B
A

F
E
D
C
E
A

1 2 3 4 5 6 7 8

8807R548