

1 2 3 4 5 6 7 8

REVISIONS		
ISS	ZONE	DESCRIPTION \ PER REQUEST \ DATE

**SALES**

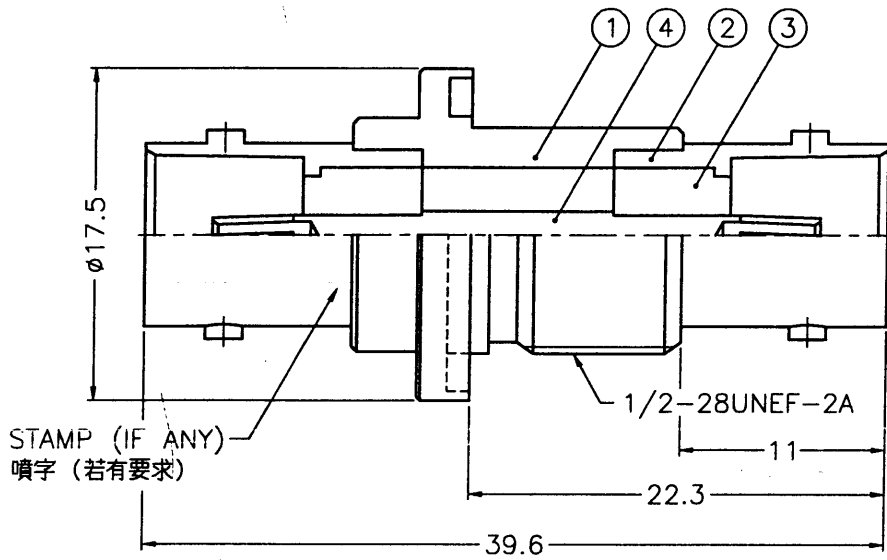

STAMP (IF ANY)  
噴字 (若有要求)

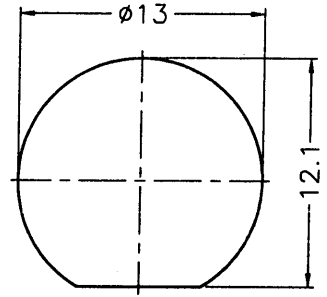
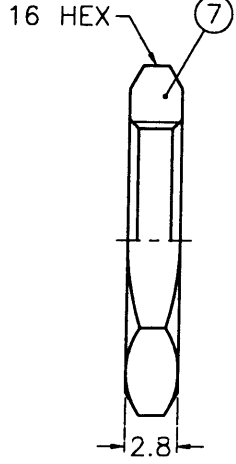
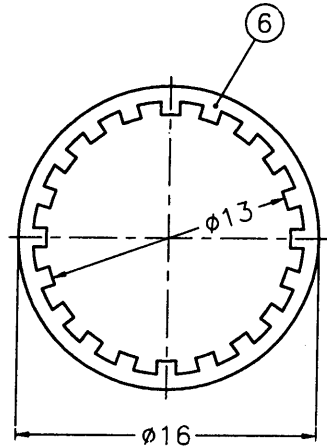
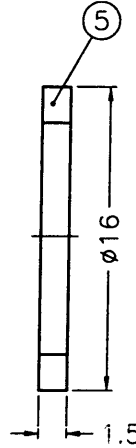

NOTES: FINISH (PLATING THICKNESS IN MICRO-INCHES)  
 1. BRASS PER QQ-B-626  
 2. BRASS PER QQ-B-613  
 3. NICKEL PL. 100 MIN. THICK OVER COPPER STRIKE  
 4. PHOSPHOR BRONZE PER QQ-B-750  
 5. GOLD PL. 3 MIN. THICK OVER NICKEL PL. 100 MIN. THICK OVER COPPER STRIKE

1. MAX. PANEL THICKNESS=7mm

RECOMMENDED MOUNTING HOLE  
(建議架設孔)

DIMENSIONS ARE IN MILLIMETERS					PART NO.		<b>Amphenol - Kai Jack</b> TAINAN TAIWAN TITLE BNC FEMALE TO FEMALE BULKHEAD ADAPTOR DRAWING NO. KJ-B7471A1-ND3G-75 ITEM NO. 017471AAA00ND7F				
7	HEX NUT	NOTE 1	NOTE 3	1	HN16-1/2-28X28	APPROVED			DATE		
6	LOCK WASHER	NOTE 2	NOTE 3	1	LW-16/13X05	<i>Angela W</i>			04-08-02'		
5	GASKET	RUBBER	RED	1	GS-16/122X15	CHECKED			DATE		
4	CONTACT PIN	NOTE 4	NOTE 5	1	B7910-4	<i>Karl Y</i>	04-08-02'				
3	INSULATOR	DELTRIN	NATURAL	2	B7996ZZ-3-75	DRAWN	DATE				
2	BODY	NOTE 1	NOTE 3	2	B74000-2	<i>Angela W</i>	04-08-02'				
1	HOUSING	NOTE 1	NOTE 3	1	B7910-1						
NO.	DESCRIPTION	MATERIAL	FINISH	Q'TY	DRAWING NO.	SCALE	2.5/1	ISSUE	A1	FILE NO.	F:\DWG\B\7471A1\75\ND3G

RD-DR 14/258

F  
E  
D  
C  
B  
A

F  
E  
D  
C  
B  
A