

1 2 3 4 5 6 7 8

REVISIONS		
ISS	ZONE	DESCRIPTION\PER REQUEST\DATE

業務部

F
E
D
C
B
A

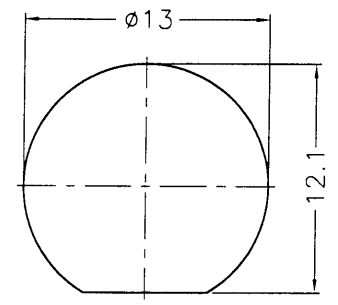
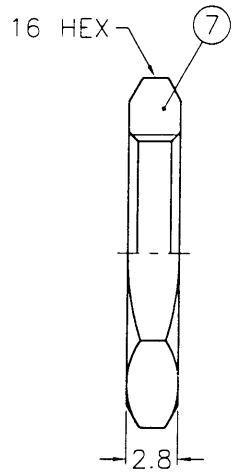
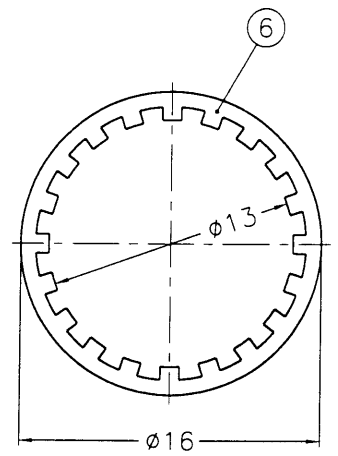
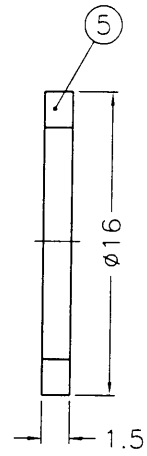
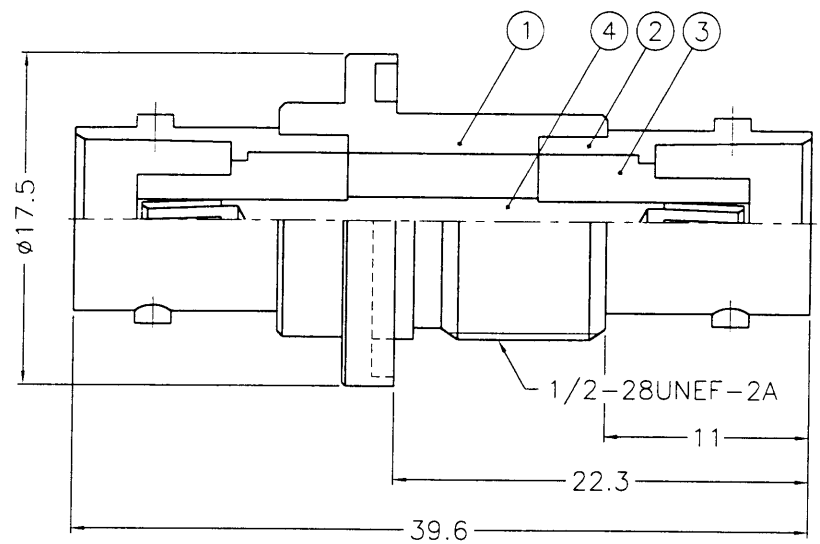

RECOMMENDED MOUNTING HOLE

88.4.28

- NOTES: FINISH (PLATING THICKNESS IN MICRO-INCHES)
- BRASS PER QQ-B-626
 - BRASS PER QQ-B-613
 - NICKEL PL. 100 MIN. THICK OVER COPPER STRIKE
 - PHOSPHOR BRONZE PER QQ-B-750
 - GOLD PL. 3 MIN. THICK OVER NICKEL PL. 100 MIN. THICK OVER COPPER STRIKE
 - TEFLON MIL-P-19468

NO.	DESCRIPTION	MATERIAL	FINISH	Q'TY	DRAWING NO.
7	HEX NUT			1	HN16-1/2-28X28
6	LOCK WASHER			1	LW-16/13X05
5	GASKET	RUBBER	RED	1	GS-16/122X15
4	CONTACT PIN			1	B7910-4
3	INSULATOR		NATURAL	2	B7996ZZ-3T-50
2	BODY			2	B74000-2
1	HOUSING			1	B7910-1

DIMENSIONS ARE IN MILLIMETERS			PART NO.	
UNLESS OTHERWISE SPECIFIED TOLERANCES			APPROVED <i>Mark C</i> DATE 04-26-99'	
0.5-6	= ±0.2		CHECKED <i>Mark C</i> DATE 04-26-99'	
6-30	= ±0.4		DRAWN <i>Betty L</i> DATE 04-26-99'	
30-120	= ±0.6		FILE NO. F:\DWG\B\7471A1\50\NT3G	
120-315	= ±1			
315-1000	= ±1.6			
1000-2000	= ±2.4			
SCALE	2.5/1	ISSUE	A	

KAI JACK INDUSTRIAL CO., LTD.
TAINAN TAIWAN R.O.C.

TITLE: BNC FEMALE TO FEMALE BULKHEAD ADAPTOR
DRAWING NO. KJ-B7471A1-NT3G-50

8807R0549

F
E
D
C
B
A

A

A

1 2 3 4 5 6 7 8