

SALES

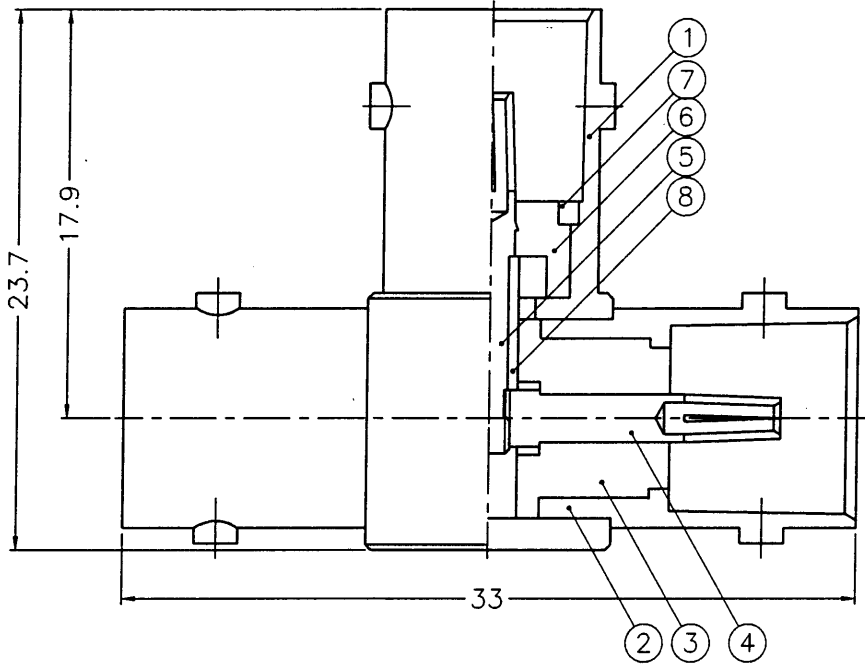

NOTES: FINISH (PLATING THICKNESS IN MICRO-INCHES)

- 1. BRASS PER QQ-B-626
- 2. NICKEL PL. 100 MIN. THICK OVER COPPER STRIKE
- 3. PHOSPHOR BRONZE PER QQ-B-750
- 4. GOLD PL. 3 MIN. THICK OVER NICKEL PL. 100 MIN. THICK OVER COPPER STRIKE

NO.	DESCRIPTION	MATERIAL	FINISH	Q'TY	DRAWING NO.	SCALE	3/1	ISSUE	B	FILE NO.	PART NO.	TITLE
8	SLEEVE	DELTRIN	NATURAL	1	SL-25/17X6	DIMENSIONS ARE IN MILLIMETERS UNLESS OTHERWISE SPECIFIED TOLERANCES 0.5-6 = ±0.2 6-30 = ±0.4 30-120 = ±0.6 120-315 = ±1 315-1000 = ±1.6 1000-2000 = ±2.4						Amphenol - Kai Jack TAINAN TAIWAN
7	LOCK RING	NOTE 1	NOTE 2	1	LR-79/62X08		APPROVED	<i>Jack E</i>	DATE	10-03-01'		
6	INSULATOR	DELTRIN	NATURAL	1	B8073A1-6-75		CHECKED	<i>Jack E</i>	DATE	10-03-01'		
5	CONTACT PIN	NOTE 3	NOTE 4	1	B8073A1-5		DRAWN	<i>Jack E</i>	DATE	10-03-01'		
4	CONTACT PIN	NOTE 3	NOTE 4	1	B7996-5							
3	INSULATOR	DELTRIN	NATURAL	2	B9073A1-4-75							
2	BODY	NOTE 1	NOTE 2	2	B9073A1-3							
1	HOUSING	NOTE 1	NOTE 2	1	B7995-1							
NO. DESCRIPTION MATERIAL FINISH Q'TY DRAWING NO. SCALE 3/1 ISSUE B FILE NO. F:\DWG\B\8073A1\75\ND3G											DRAWING NO.	KJ-B8073A1-ND3G-75
											ITEM NO.	018073AAA00ND7F

RD-DR-907