

REVISIONS		
ISS	ZONE	DESCRIPTION\PER REQUEST\DATE
A	A-7	BM-L-FMEM-NT3G-50 WAS FME2072B1-50 \CN-BS-9800\10-27-99'

業務部

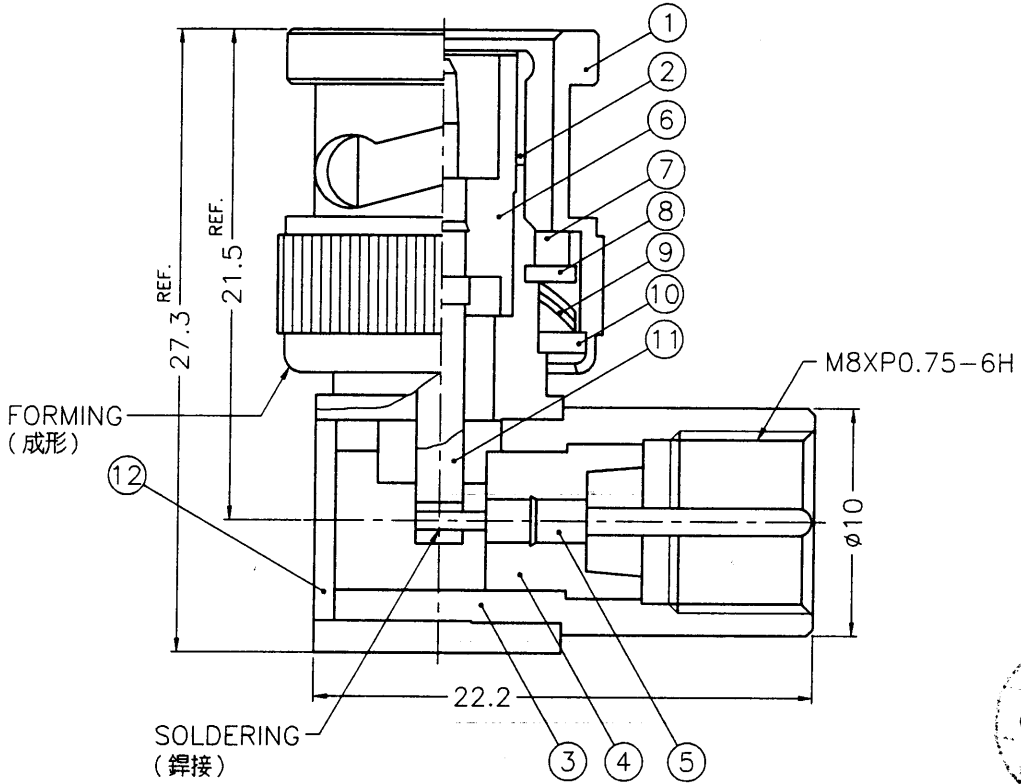

NOTES: FINISH (PLATING THICKNESS IN MICRO-INCHES)
 1. BRASS PER QQ-B-626
 2. BRASS PER QQ-B-613
 3. NICKEL PL. 100 MIN. THICK OVER COPPER STRIKE
 4. NICKEL PL. 200 MIN. THICK OVER COPPER STRIKE
 5. GOLD PL. 3 MIN. THICK OVER NICKEL PL. 100 MIN. THICK OVER COPPER STRIKE
 6. TEFLON MIL-P-19468



12	COVER	NOTE 2	NOTE 3	1	CV-895X07-T
11	CONTACT PIN	NOTE 1	NOTE 5	1	B5091-6-50
10	WASHER	NOTE 2	NOTE 3	1	WS-128/9X08
9	SPRING	SK5	NOTE 4	2	B50000-6
8	RETAINER RING	NOTE 1	NOTE 3	1	B50000-5
7	GASKET	RUBBER	RED	1	GS-115/8X15
6	INSULATOR	NOTE 6	NATURAL	1	ATC B-3000-3T-50
5	CONTACT PIN	NOTE 1	NOTE 5	1	FME2072B1-5
4	INSULATOR	NOTE 6	NATURAL	1	FME2072B1-4T-50
3	BODY	NOTE 1	NOTE 3	1	FME2072B1-3
2	HOUSING	NOTE 1	NOTE 3	1	B7996-2
1	SHELL	NOTE 1	NOTE 3	1	B50000-1-B

DIMENSIONS ARE IN MILLIMETERS
 UNLESS OTHERWISE SPECIFIED TOLERANCES
 0.5-6 = ±0.2
 6-30 = ±0.4
 30-120 = ±0.6
 120-315 = ±1
 315-1000 = ±1.6
 1000-2000 = ±2.4

PART NO.	
APPROVED	DATE 10-27-99'
CHECKED	DATE 10-27-99'
DRAWN	DATE 10-27-99'

Amphenol - Kai Jack	
TAINAN TAIWAN	
TITLE	BNC MALE TO FME MALE R/A ADAPTOR
DRAWING NO.	BM-L-FMEM-NT3G-50
FILE NO.	F:\DWG\BM\L\FMEM\50\NT3G

NO.	DESCRIPTION	MATERIAL	FINISH	Q'TY	DRAWING NO.
-----	-------------	----------	--------	------	-------------

8012873