

1 2 3 4 5 6 7 8

REVISIONS		
ISS	ZONE	DESCRIPTION\PER REQUEST\DATE
A2	A-3	NO.3 WAS CHANGED\N/A\05-31-02'

**SALES**

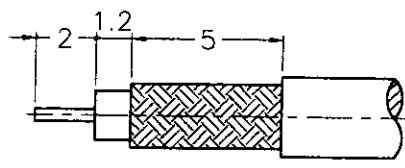

RECOMMENDED  
CABLE (STRIPPING) DIM'S  
(建議剝線尺寸)

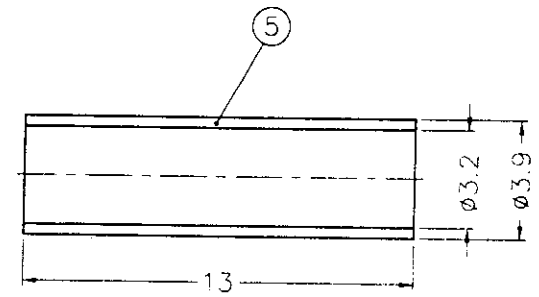
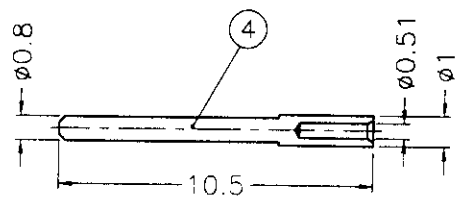
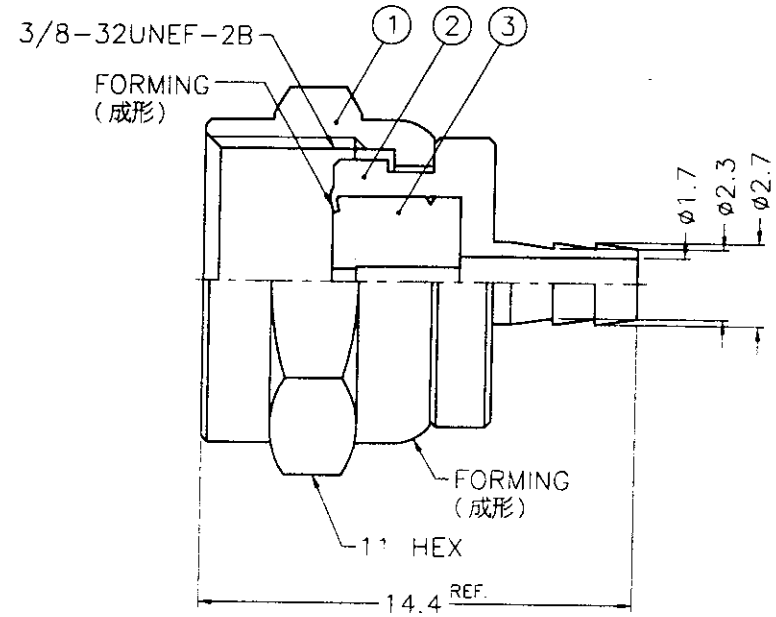

ISSUED  
2002. 6. 04  
R&D

1. CRIMPED FERRULE  
HEX. CRIMP SIZE .128"

- NOTES: FINISH (PLATING THICKNESS IN MICRO-INCHES)
- BRASS PER QQ-B-626
  - TIN-LEAD (90/10) PL. 100 MIN. THICK OVER NICKEL PL. 50 MIN. THICK OVER COPPER PL. 100 MIN. THICK
  - BRIGHT TIN PL. 200 MIN. THICK OVER NICKEL PL. 50 MIN. THICK OVER COPPER PL. 100 MIN. THICK
  - TEFLON MIL-P-19468
  - JIS H 3250, C 2600

DIMENSIONS ARE IN MILLIMETERS					PART NO.		Amphenol - Kai Jack	
5	FERRULE	NOTE 5	NOTE 2	1	FR-39/32X13	APPROVED	DATE	TAINAN TAIWAN
4	CONTACT PIN	NOTE 1	NOTE 3	1	CP04AAG05A	<i>Mark C</i>	05-31-02'	TITLE F CRIMP PLUG
3	INSULATOR	NOTE 4	NATURAL	1	NS00AUM01A	CHECKED	DATE	(FOR RG-179/U,187A/U)
2	BODY	NOTE 1	NOTE 2	1	SA-003-09-2-B	<i>Karl J.</i>	05-31-02'	DRAWING NO.
1	SHELL	NOTE 1	NOTE 2	1	SA-003-09-1-B	<i>Angela W</i>	05-31-02'	KJ-F1111A1-004-TTT-75
NO.	DESCRIPTION	MATERIAL	FINISH	Q'TY	DRAWING NO.	SCALE	4/1	ISSUE
						A2		FILE NO. F:\DWG\F\1111A1\004\75\TTT
								ITEM NO. 041111AAJ19TB7F

7RD-DR-14615 8

F  
E  
D  
C  
B  
A

F  
E  
D  
C  
B  
A

1 2 3 4 5 6