

REVISIONS		
ISS	ZONE	DESCRIPTION\APPROVED\DATE

業務部

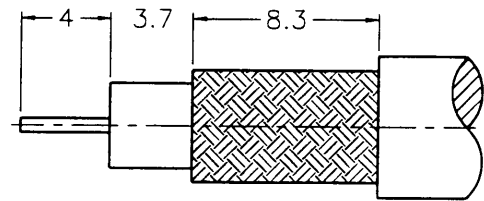

RECOMMENDED  
CABLE STRIPPING DIM'S

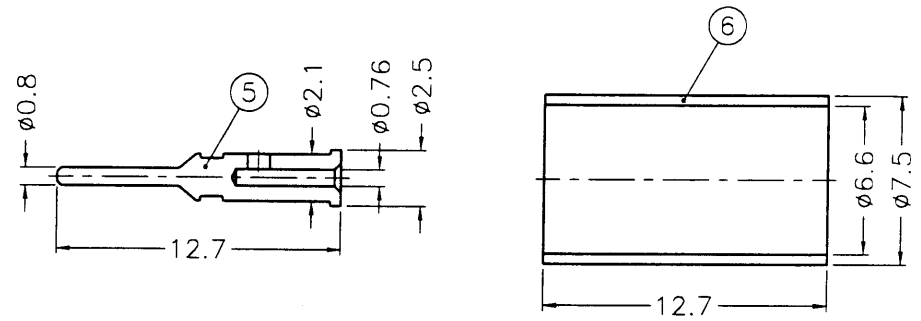
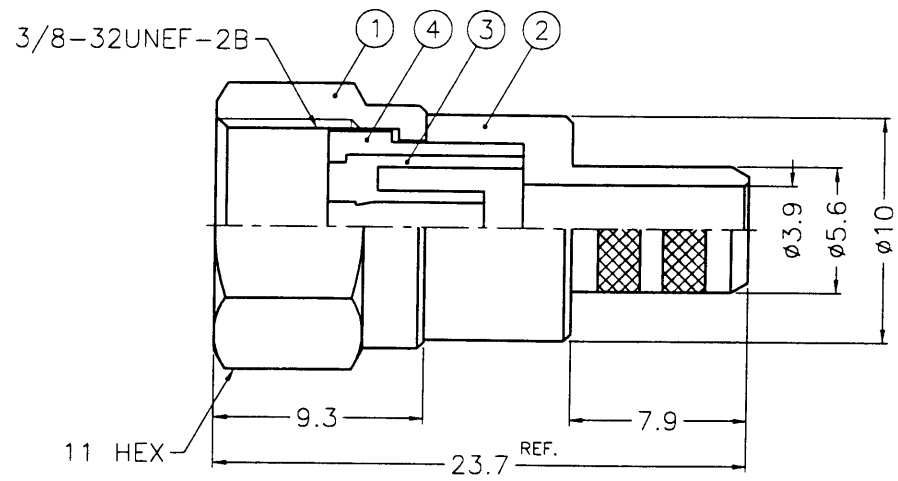

NOTES: FINISH (PLATING THICKNESS IN MICRO-INCHES)  
 1. BRASS PER QQ-B-626  
 2. NICKEL PL. 100 MIN. THICK OVER COPPER STRIKE  
 3. GOLD PL. 3 MIN. THICK OVER NICKEL PL. 100 MIN. THICK OVER COPPER STRIKE  
 4. JIS H 3250, C 2700

出圖  
87.9.30  
R&D

NO.	DESCRIPTION	MATERIAL	FINISH	Q'TY	DRAWING NO.	SCALE	3/1	ISSUE	A	PART NO.	APPROVED	DATE	TITLE
6	FERRULE			1	FR-75/66X127	DIMENSIONS ARE IN MILLIMETERS							<b>KAI JACK INDUSTRIAL CO., LTD.</b> TAINAN TAIWAN R.O.C.  F CRIMP PLUG  DRAWING NO. KJ-F1121A1-ND3G-59U-75 FILE NO. F:\DWG\F\1121A1\59U-75\ND3G
5	CONTACT PIN			1	FP-5CFB-K-5-25/076	UNLESS OTHERWISE SPECIFIED TOLERANCES							
4	BODY			1	FP-5CFB-K-4-B	0.5-6 = ±0.2							
3	INSULATOR	DELTRIN	NATURAL	1	FP-5CFB-K-3-A	6-30 = ±0.4							
2	BARREL			1	FP-3C-K-2-56/39	30-120 = ±0.6							
1	SHELL			1	FP-5CFB-K-1-A	120-315 = ±1							
						315-1000 = ±1.6							
						1000-2000 = ±2.4							

APPROVED *Mark C* DATE 09-29-98'  
 CHECKED *Cons. W* DATE 09-29-98'  
 DRAWN *Cons. W* DATE 09-29-98'