

業務部

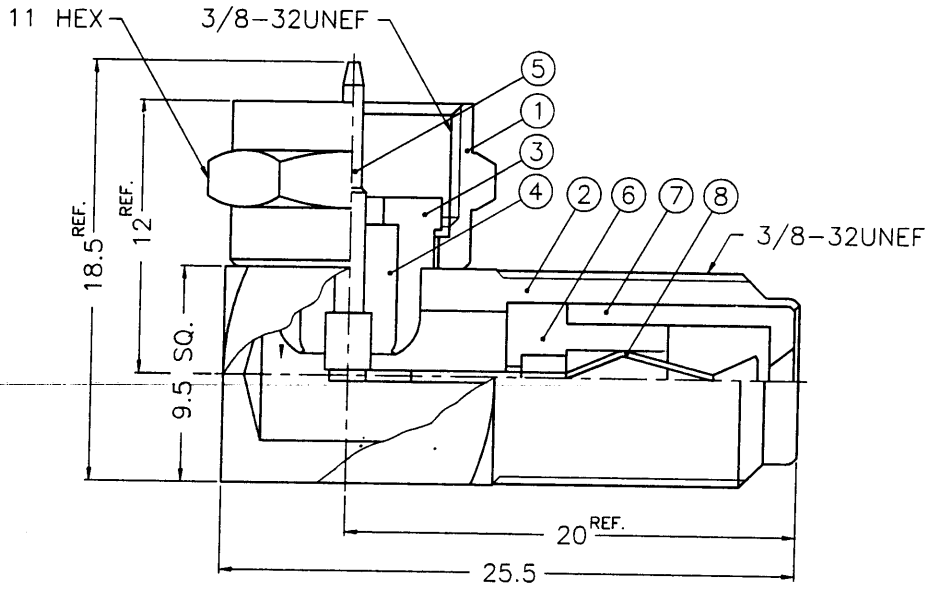

NOTES: FINISH (PLATING THICKNESS IN MICRO-INCHES)
 1. BRASS PER QQ-B-626
 2. NICKEL PL. 80 MIN. THICK OVER COPPER STRIKE
 3. BRIGHT TIN PL. 80 MIN. THICK OVER COPPER PL. 100 MIN.
 4. PHOSPHOR BRONZE PER QQ-B-750



NO.	DESCRIPTION	MATERIAL	FINISH	Q'TY	DRAWING NO.
8	CONTACT PIN	NOTE 4	NOTE 3	1	
7	INSULATOR	P.P.	NATURAL	1	
6	INSULATOR	P.P.	NATURAL	1	
5	CONTACT PIN	NOTE 1	NOTE 2	1	
4	INSULATOR	DELTRIN	NATURAL	1	
3	BODY	NOTE 1	NOTE 2	1	
2	HOUSING	NOTE 1	NOTE 2	1	
1	SHELL	NOTE 1	NOTE 2	1	

DIMENSIONS ARE IN MILLIMETERS			
UNLESS OTHERWISE SPECIFIED TOLERANCES			
0.5-6	=	±0.2	
6-30	=	±0.4	
30-120	=	±0.6	
120-315	=	±1	
315-1000	=	±1.6	
1000-2000	=	±2.4	

PART NO.	
APPROVED	DATE
CHECKED	DATE
DRAWN	DATE

Amphenol - Kai Jack	
TAINAN TAIWAN	
TITLE	
F MALE TO FEMALE R/A ADAPTOR	
DRAWING NO.	
KJ-F5072A2-NPPT-75	
FILE NO. F:\DWG\F\5072A2\75\NPPT	

Mark C
 11-08-99'
Case 2
 11-08-99'
Betty L
 11-08-99'

8F-2714