

REVISIONS		
ISS	ZONE	DESCRIPTION\PER REQUEST\DATE

REMARK: 1. SOLDER PIN WITHOUT ROTATION MUST WITHSTAND 0.4 Kg-cm TORQUE MIN.
 (焊接端的中心針轉 . 至少須承受 0.4 Kg-cm 的扭力, 不可旋轉)
 2. ACCEPTS $\phi 0.51 \sim \phi 1.19$ CENTER CONDUCTOR TYPICAL
 (允許 $\phi 0.51 \sim \phi 1.19$ 的中心導針)

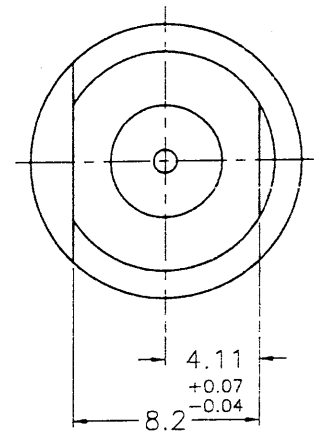
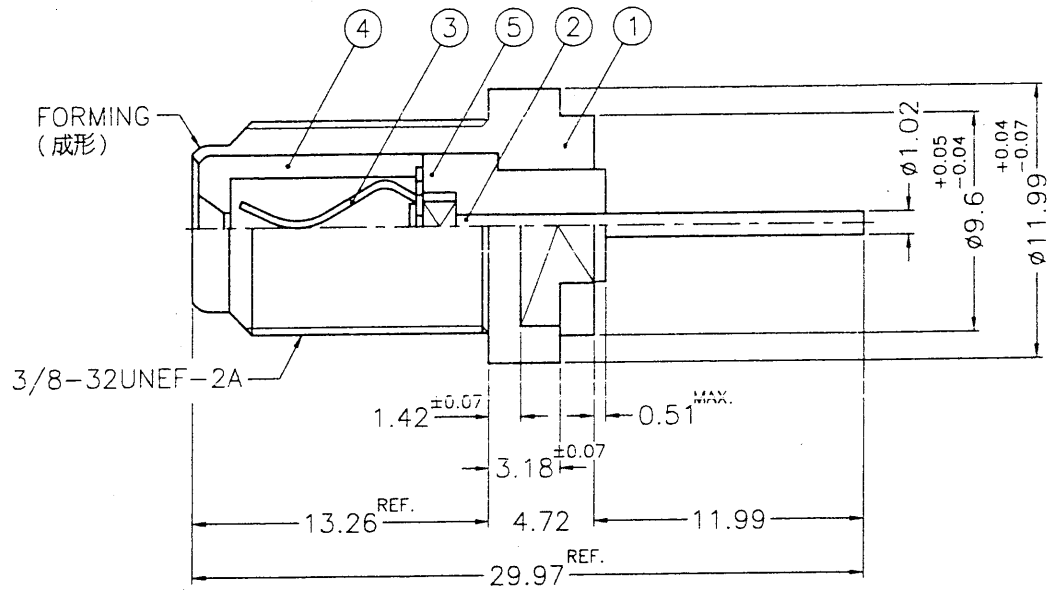

NOTES: FINISH (PLATING THICKNESS IN MICRO-INCHES)
 1. BRASS PER QQ-B-626
 2. BERYLLIUM COPPER PER QQ-C-530
 3. NICKEL PL. 100 MIN. THICK OVER COPPER STRIKE
 4. BRIGHT TIN PL. 100 MIN. THICK OVER NICKEL PL. 50 MIN. THICK OVER COPPER PL. 100 MIN.
 5. PHOSPHOR BRONZE PER QQ-B-750

NO.	DESCRIPTION	MATERIAL	FINISH	Q'TY	DRAWING NO.
5	INSULATOR	P.P.	NATURAL	1	NS00AU02A
4	INSULATOR	P.P.	BLUE	1	NS00ATZ01A
3	CONTACT PIN	NOTE 2	NOTE 4	1	CP04ABC01A
2	SOLDER PIN	NOTE 5	NOTE 4	1	SD00AAA02A
1	BODY	NOTE 1	NOTE 3	1	BD04ABV02A

DIMENSIONS ARE IN MILLIMETERS				PART NO. -0001	
UNLESS OTHERWISE SPECIFIED TOLERANCES				APPROVED <i>A.K.C.</i>	DATE 04-30-02'
0.5-6 = ±0.2				CHECKED <i>Karl J.</i>	DATE 04-30-02'
6-30 = ±0.4				DRAWN ANGELA	DATE 04-30-02'
30-120 = ±0.6				FILE NO. F:\DWG\F\6051A1\002\75\NPPT	
120-315 = ±1					
315-1000 = ±1.0					
1000-2000 = ±2.4					

Amphenol - Kai Jack	
TAINAN TAIWAN	
TITLE F RECEPT. JACK	
DRAWING NO. KJ-F6051A1-002-NPPT-75	
ITEM NO.	