

REVISIONS			
ISS	ZONE	DESCRIPTION\PER REQUEST\DATE	

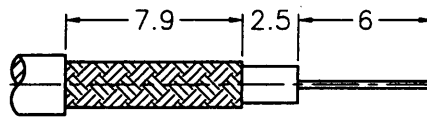

RECOMMENDED
CABLE STRIPPING DIM'S
(建議剝線尺寸)

SALES

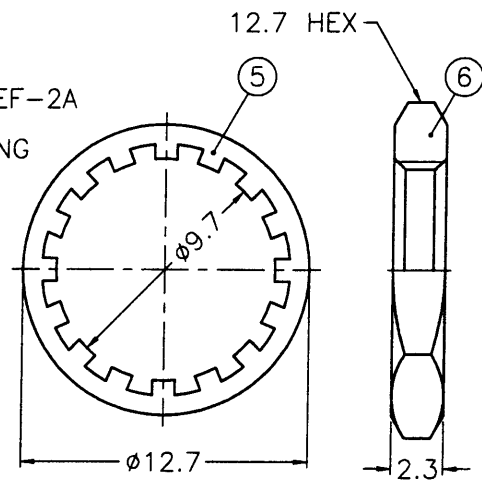
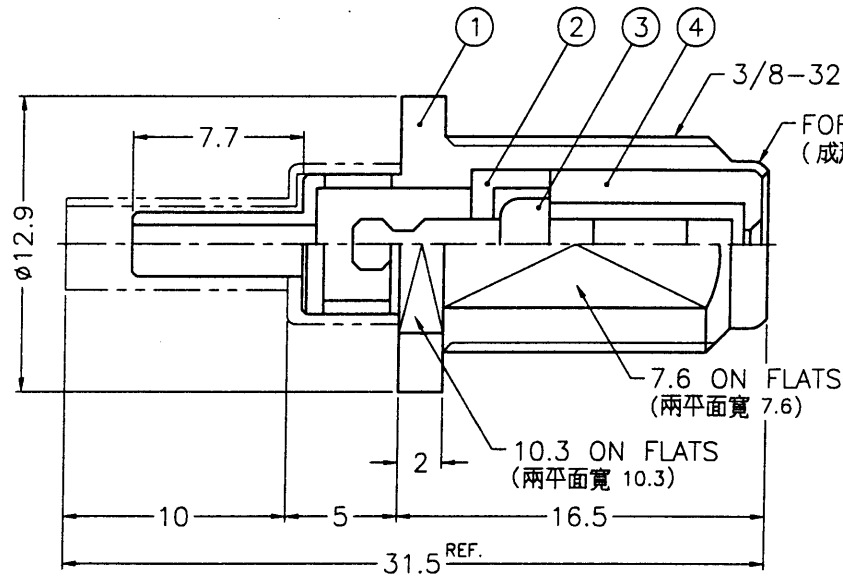
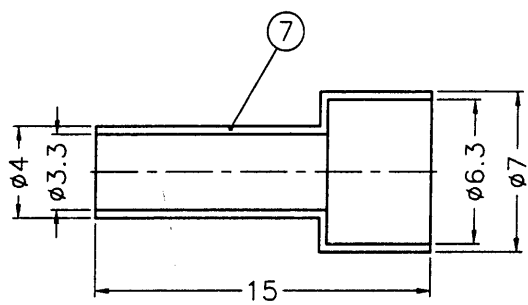

NOTES: FINISH (PLATING THICKNESS IN MICRO-INCHES)

- BRASS PER QQ-B-626
- BRASS PER QQ-B-613
- TIN-LEAD (90/10) PL. 100 MIN. THICK OVER NICKEL PL. 50 MIN. THICK OVER COPPER PL. 100 MIN. THICK
- BRIGHT TIN PL. 200 MIN. THICK OVER NICKEL PL. 50 MIN. THICK OVER COPPER PL. 100 MIN. THICK

ISSUED
2001.12.11
R & D

- CRIMPED FERRULE
HEX CRIMP SIZE .128"
- CONTACT PIN TO SOLDER
- MAX. PANEL THICKNESS=4.5mm

NO.	DESCRIPTION	MATERIAL	FINISH	Q'TY	DRAWING NO.
7	FERRULE	NOTE 1	NOTE 3	1	FR-7/63-4/33X X15
6	HEX NUT	NOTE 1	NOTE 3	1	HN127-3/8-32X 23
5	LOCK WSHR	NOTE 2	NOTE 3	1	LW-127/97X05
4	INSULATOR	P.P.	NATURAL	1	222114-234-
3	CONTACT PIN	NOTE 2	NOTE 4	1	PPT
2	INSULATOR	P.P.	NATURAL	1	
1	BODY	NOTE 1	NOTE 3	1	222114-1

DIMENSIONS ARE IN MILLIMETERS				PART NO.	
UNLESS OTHERWISE SPECIFIED TOLERANCES				APPROVED	DATE
0.5-6	= ±0.2			<i>Andy C</i>	12-07-01'
6-30	= ±0.4				
30-120	= ±0.6			CHECKED	DATE
120-315	= ±1			<i>Andy C</i>	12-07-01'
315-1000	= ±1.6			DRAWN	DATE
1000-2000	= ±2.4			<i>Shaly W</i>	12-07-01'
SCALE	3/1	ISSUE	A1	FILE NO.	F:\DWG\F\6411A1\002\179U\TPPT

Amphenol - Kai Jack	
TAINAN TAIWAN	
TITLE	F BULKHEAD CRIMP JACK
DRAWING NO.	KJ-F6411A1-002-TPPT-179U
ITEM NO.	046411AAG19TF7F