

1 2 3 4 5 6 7 8

REVISIONS		
ISS	ZONE	DESCRIPTION\PER RERQUEST\DATE

業務部

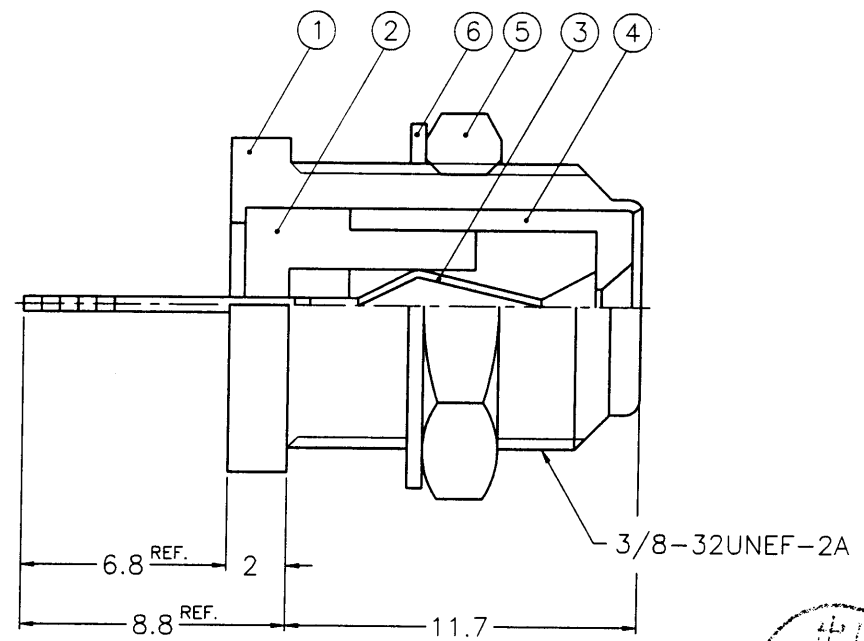
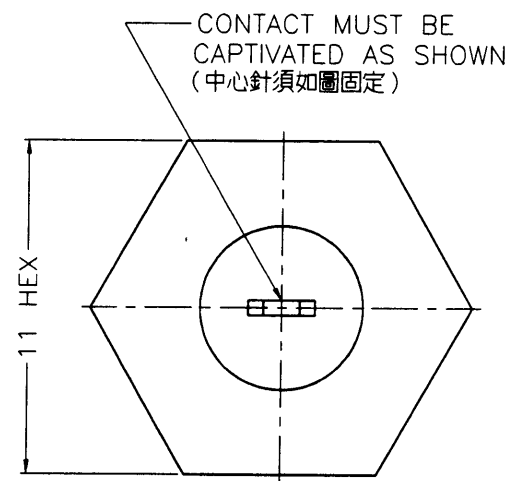

NOTES: FINISH (PLATING THICKNESS IN MICRO-INCHES)  
 1. BRASS PER QQ-B-626  
 2. BRASS PER QQ-B-613  
 3. NICKEL PL. 80 MIN. THICK OVER COPPER STRIKE  
 4. GOLD FLASH OVER NICKEL PL. 100 MIN. THICK OVER COPPER STRIKE



DIMENSIONS ARE IN MILLIMETERS						PART NO.		Amphenol - Kai Jack	
UNLESS OTHERWISE SPECIFIED TOLERANCES						APPROVED		TAINAN TAIWAN	
6	LOCK WASHER	NOTE 2	NOTE 3	1	F7900-4	DATE 11-17-99'		TITLE	
5	HEX NUT	NOTE 1	NOTE 3	1	F7900-5	DATE 11-17-99'		F CONNECTOR	
4	INSULATOR	P.P.	NATURAL	1		DATE 11-17-99'		DRAWING NO.	
3	CONTACT PIN	NOTE 1	NOTE 4	1		DATE 11-17-99'		KJ-F6451A2-NPP3G-75	
2	INSULATOR	P.P.	NATURAL	1		DATE 11-17-99'		FILE NO.	
1	BODY	NOTE 1	NOTE 3	1		DATE 11-17-99'		F:\DWG\F\6451A2\75\NPP3G	
NO.	DESCRIPTION	MATERIAL	FINISH	Q'TY	DRAWING NO.	SCALE	4/1	ISSUE	A

1 2 3 4 5 6 7 8

8F R0013