

業務部

REVISIONS		
NO.	DESCRIPTION	DATE

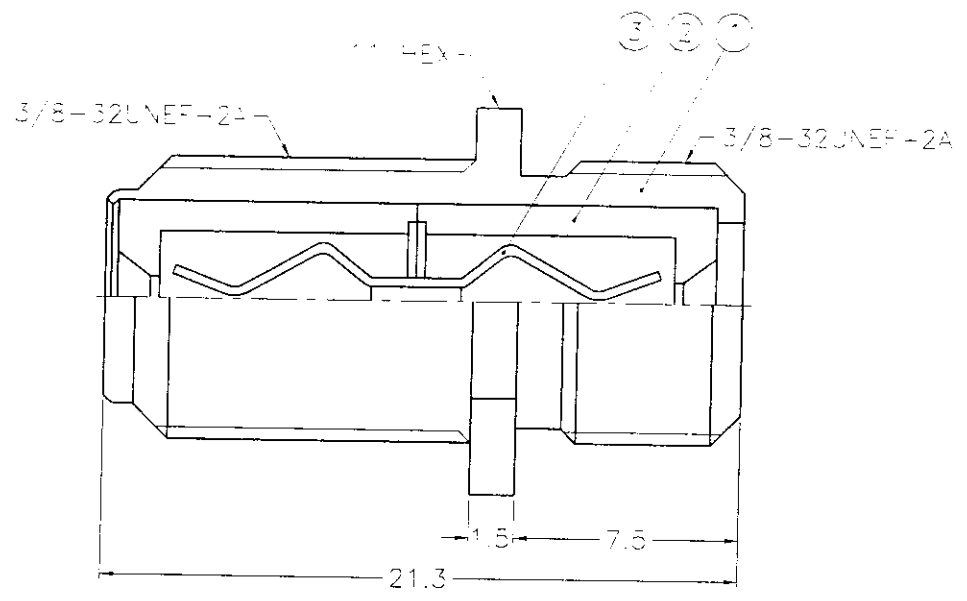
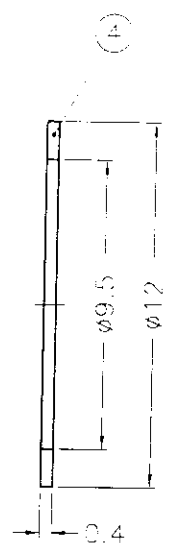
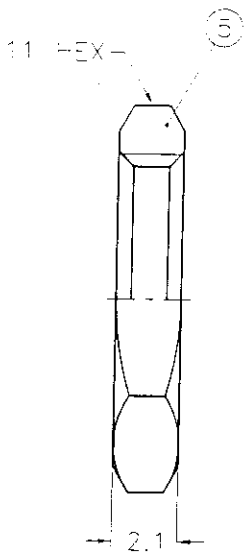

NOTES: FINISH (PLATING THICKNESS IN MICRO-INCHES)
 1. BRASS PER QQ-B-626
 2. BRASS PER QQ-B-613
 3. NICKEL PL. 80 MIN. THICK OVER COPPER STRIKE
 4. NICKEL PL. 80 MIN. THICK OVER COPPER PL. 300 MIN. THICK
 5. BRIGHT TIN PL. 80 MIN. THICK OVER NICKEL PL. 50 MIN. THICK OVER COPPER PL. 100 MIN. THICK

出圖
87.8.04
R&D

DIMENSIONS ARE IN MILLIMETERS	
UNLESS OTHERWISE SPECIFIED TOLERANCES	
0.5-6	±0.2
6-30	±0.4
30-120	±0.6
120-315	±1
315-1000	±1.6
1000-2000	±2.4

PART NO.	
APPROVED	DATE
CHECKED	DATE
DRAWN	DATE

Mark C
Mark C
alex.H

08-03-98
08-03-98
08-03-98

 KAI JACK INDUSTRIAL CO., LTD. TAINAN, TAIWAN, R.O.C.	
TITLE	
DRAWING NO.	
FILE NO.	

F CONNECTOR
KJ-F7900Z-NPPT
F:\DWG\FV7900Z\NPPT

NO.	DESCRIPTION	MATERIAL	FINISH	QTY	DRAWING NO.
5	HEX NUT		NOTE 1	1	HN11-3/8-32X21
4	WASHER		NOTE 2	1	WS-12/95X04
3	CONTACT PIN		NOTE 3	1	F7900-NPPT-G
2	INSULATOR	P.P.	NATURAL	2	
1	BODY	DIECAST	NOTE 4	1	

8F-R06Y1