

REVISIONS			
ISS	ZONE	DESCRIPTION	PER REQUEST DATE

REMARK: 1. BETWEEN NO.4 AND NO.6 MUST WITHSTAND A 50 lbs. MIN. SEPARATED FORCE.
(1. 零件4及零件6至少須承受 50 磅的脫離力量)

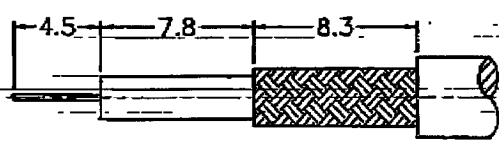

RECOMMENDED
CABLE STRIPPING DIM'S
(建議剝線尺寸)

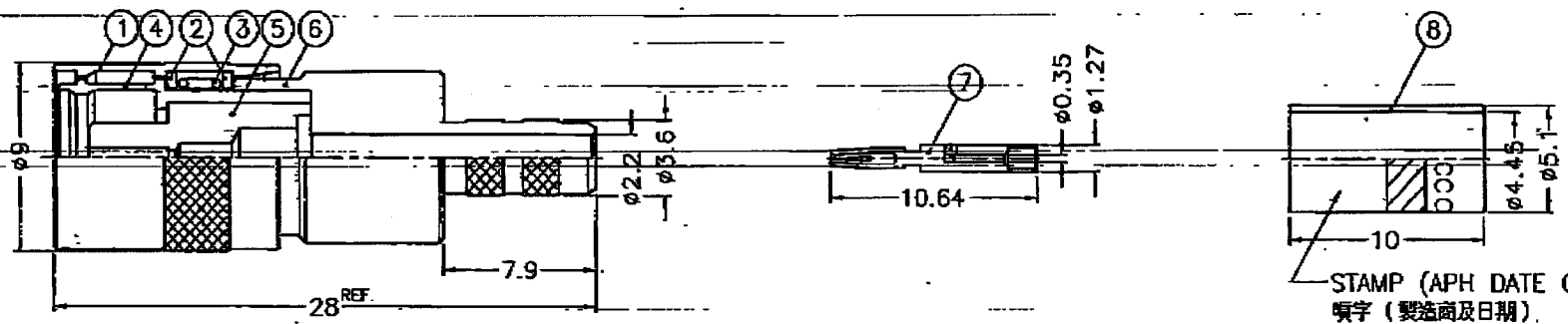

STAMP (APH DATE CODE)
噴字 (製造商及日期)

- NOTES: FINISH (PLATING THICKNESS IN MICRO-INCHES)
- BRASS PER QQ-B-626
 - NICKEL PL. 100 MIN. THICK OVER COPPER STRIKE
 - GOLD PL. 3 MIN. THICK OVER NICKEL PL. 100 MIN. THICK OVER COPPER STRIKE
 - BERYLLIUM COPPER PER QQ-C-530
 - PHOSPHOR BRONZE PER QQ-B-750
 - COLD PL. 30 MIN. THICK OVER NICKEL PL. 100 MIN. THICK OVER COPPER STRIKE
 - TEFLON ML-P-19468
 - JIS H 3250, C 2700

- CRIMPED FERRULE
HEX CRIMP SIZE .178"
- CONTACT PIN TO SOLDER OR
USE DMC-MH800(GB109) CRIMP TOOL
- SOCKET HDC43/SFS

9	POSITIONER	DELFIN	NATURAL	D.05	PST-BT43
8	FERRULE	NOTE 8	NOTE 2	1	FR-51/445X10-BLA
7	CONTACT PIN	NOTE 5	NOTE 6	1	H436121B2-7-127/035
6	BARREL	NOTE 1	NOTE 2	1	H436121B2-6-38/22
5	INSULATOR	NOTE 7	NATURAL	1	H436121B2-5T-75
4	BODY	NOTE 1	NOTE 2	1	H436121B2-4
3	SPRING	SUS. 304	NATURAL	1	H436121B2-3-SPR
2	RING	NOTE 4	NATURAL	2	H436121B2-2
1	SHELL	NOTE 1	NOTE 2	1	H436121B2-1
NO.	DESCRIPTION	MATERIAL	FINISH	QTY	DRAWING NO.

DIMENSIONS ARE IN MILLIMETERS		PART NO.	
UNLESS OTHERWISE SPECIFIED TOLERANCES		APPROVED	DATE
0.5-6	±0.2	gawcky gawcky JACKY	06-11-01'
6-30	±0.4		DATE
30-120	±0.6	CHECKED	06-11-01'
120-315	±1	DRAWN	DATE
315-1000	±1.6		06-11-01'
1000-2000	±2.4		
SCALE	3/1	ISSUE	1

Amphenol - Kai Jack	
TAINAN TAIWAN	
TITLE	HDC43 POSITION LOCK CRIMP SOCKET (FOR BT3002/TZC75024 CABLE)
DRAWING NO.	KJ-H436121B2- T30G-3002-75
FILE NO.	F:\DWG\H43\6121B2\3002-75\N10CT30G