

| 1 REVISIONS |                              |
|-------------|------------------------------|
| ISS ZONE    | DESCRIPTION\PER REQUEST\DATE |
|             |                              |

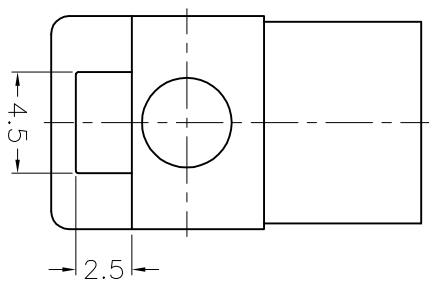
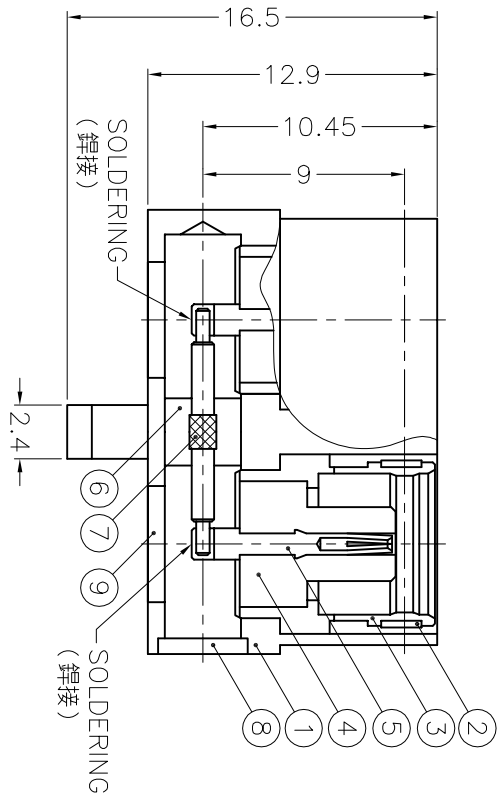
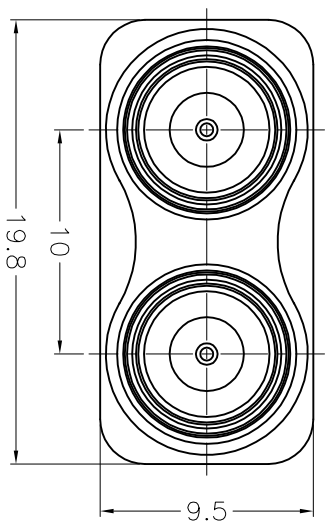

1. LINK HDC43/10A

- NOTES: FINISH (PLATING THICKNESS IN MICRO-INCHES)
1. BRASS PER QQ-B-626
  2. GOLD PL. 3 MIN. THICK OVER NICKEL PL. 100 MIN. THICK OVER COPPER STRIKE
  3. NICKEL PL. 100 MIN. THICK OVER COPPER STRIKE
  4. NICKEL PL. 100 MIN. THICK OVER COPPER PL. 500 MIN. THICK
  5. GOLD PL. 30 MIN. THICK OVER NICKEL PL. 100 MIN. THICK OVER COPPER STRIKE
  6. TEFLON MIL-P-19468
  7. ZINC DIECAST
  8. BERYLLIUM COPPER PER QQ-C-530
  9. BRASS PER QQ-B-613

| 9 COVER         | NOTE 9 | NOTE 3  | 2 | CV-523X06-T-B |
|-----------------|--------|---------|---|---------------|
| 8 COVER         | NOTE 9 | NOTE 3  | 1 | CV-4X05-T     |
| 7 POST          | NOTE 1 | NOTE 5  | 1 | PS00AAD03A    |
| 6 INSULATOR     | NOTE 6 | NATURAL | 1 | NS00AGM38A    |
| 5 CONTACT PIN   | NOTE 8 | NOTE 5  | 2 | CP43AAQ01A    |
| 4 INSULATOR     | NOTE 6 | NATURAL | 2 | NS43AAP01A    |
| 3 BODY          | NOTE 1 | NOTE 2  | 2 | BD44AAF01A    |
| 2 RETAINER RING | NOTE 8 | NATURAL | 2 | SMBS003-8-75  |
| 1 HOUSING       | NOTE 7 | NOTE 4  | 1 | HS00ALY01A    |

DIMENSIONS ARE IN MILLIMETERS  
UNLESS OTHERWISE SPECIFIED  
TOLERANCES  
0.5-6 = ±0.2  
6-30 = ±0.4  
30-120 = ±0.6  
120-315 = ±1  
315-1000 = ±1.6  
1000-2000 = ±2.4

| PART NO. |      |
|----------|------|
| APPROVED | DATE |
| CHECKED  | DATE |
| DRAWN    | DATE |

| TITLE                                       |                       |
|---|-----------------------|
| Danbury,CT,USA-Tainan,Taiwan-Shenzhen,China |                       |
| <b>Amphenol</b>                             |                       |
| HDC43 U-LINK ADAPTOR                        |                       |
| DRAWING NO.                                 | H437076D1-N/3GT30G-75 |
| ITEM NO.                                    | 447076AAAA1NP7F       |

1 2 3 4 5 6 7 8