

1 2 3 4 5 6 7 8

REVISIONS			
ISS	ZONE	DESCRIPTION\PER	REQUEST\DATE

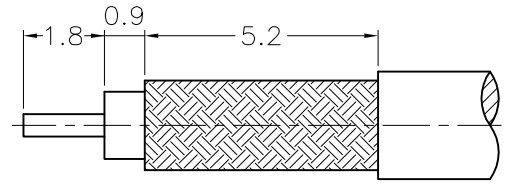

RECOMMENDED  
CABLE STRIPPING DIM'S  
(建議剝線尺寸)

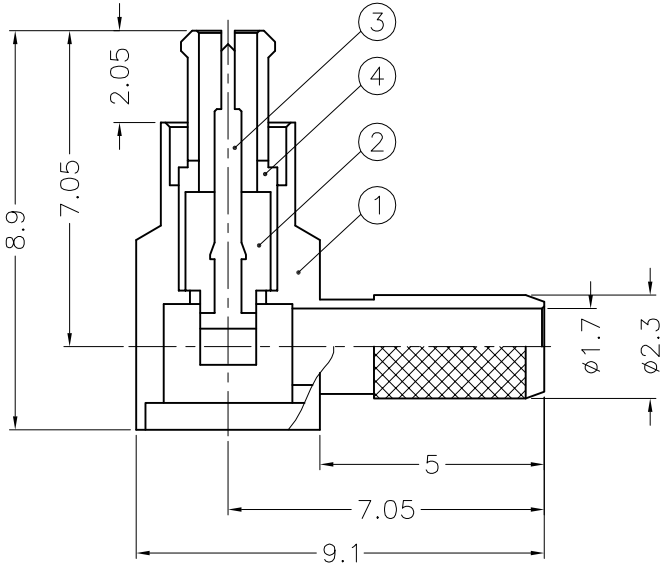
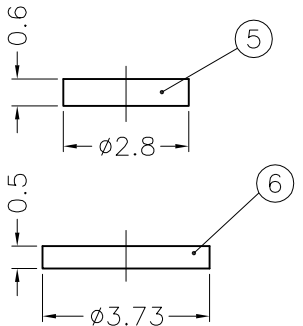
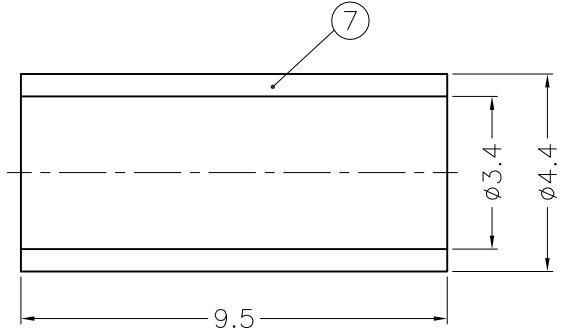

NOTES: FINISH (PLATING THICKNESS IN MICRO-INCHES)  
 1. BRASS PER QQ-B-626  
 2. BRASS PER QQ-B-613  
 3. BERYLLIUM COPPER PER QQ-C-530  
 4. NICKEL PL. 100 MIN. THICK OVER COPPER STRIKE  
 5. GOLD PL. 3 MIN. THICK OVER NICKEL PL. 100 MIN. THICK OVER COPPER STRIKE  
 6. TEFLON MIL-P-19468

1. CRIMPED FERRULE  
 HEX. CRIMP SIZE .151"  
 2. CONTACT PIN TO SOLDER

DIMENSIONS ARE IN MILLIMETERS					PART NO.		<h2 style="text-align: center;">Amphenol - Kai Jack</h2> <p style="text-align: center;">TAINAN TAIWAN</p>			
UNLESS OTHERWISE SPECIFIED TOLERANCES					APPROVED	DATE			TITLE	
7	FERRULE	COPPER	NOTE 4	1	FR-44/34X95C	ANGELA			03-07-02'	MC-CARD R/A PLUG
6	COVER	NOTE 2	NOTE 4	1	CV-373X05					DRAWING NO.
5	INSULATOR	NOTE 6	NATURAL	1	MCC1182A1-5	CHECKED	03-07-02'	ITEM NO.		
4	OUTER CONTACT	NOTE 3	NOTE 5	1	MCC1182A1-4	DRAWN	03-07-02'			
3	CONTACT PIN	NOTE 1	NOTE 5	1	MCC1182A1-3	FILE NO.	F:\DWG\MCC\1112A1\316UD-50\N3GT3G			
2	INSULATOR	NOTE 6	NATURAL	1	MCC1182A1-2					
1	BODY	NOTE 1	NOTE 4	1	BD00AQB01A					
NO.	DESCRIPTION	MATERIAL	FINISH	Q'TY	DRAWING NO.	SCALE	6/1	ISSUE	A1	

1 2 3 4 5 6 7 8

F  
E  
D  
C  
B  
A

F  
E  
D  
C  
B  
A