

REVISIONS

ISS	ZONE	DESCRIPTION\PER REQUEST\DATE

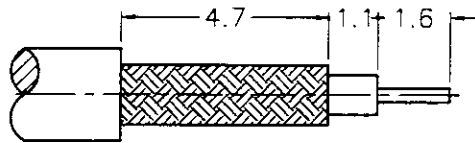

RECOMMENDED
CABLE STRIPPING DIM'S
(建議剝線尺寸)

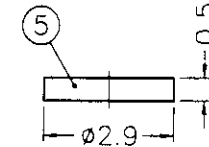
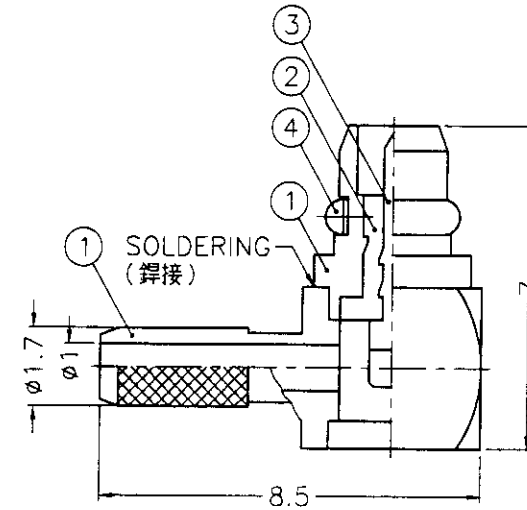
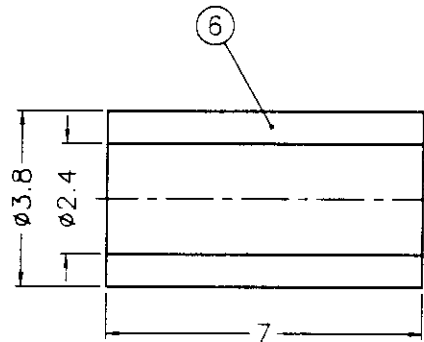

NOTES: FINISH (PLATING THICKNESS IN MICRO-INCHES)

- BRASS PER QQ-B-626
- BRASS PER QQ-B-613
- GOLD PL. 3 MIN. THICK OVER NICKEL PL. 100 MIN. THICK OVER COPPER STRIKE
- BERYLLIUM COPPER PER QQ-C-530
- GOLD PL. 30 MIN. THICK OVER NICKEL PL. 100 MIN. THICK OVER COPPER STRIKE
- TEFLON MIL-P-19468



- CRIMPED FERRULE
HEX. CRIMP SIZE .128"
- CONTACT PIN TO SOLDER

NO.	DESCRIPTION	MATERIAL	FINISH	Q'TY	DRAWING NO.	SCALE	6/1	ISSUE	1	FILE NO.	F:\DWG\MMCX\1112A1\012\50\3GT30G		
6	FERRULE	COPPER	NOTE 3	1	FR-3B/24X7C	DIMENSIONS ARE IN MILLIMETERS UNLESS OTHERWISE SPECIFIED TOLERANCES 0.5-6 = ±0.2 6-30 = ±0.4 30-120 = ±0.6 120-315 = ±1 315-1000 = ±1.6 1000-2000 = ±2.4	PART NO.		Amphenol - Kai Jack TAINAN TAIWAN TITLE MMCX R/A CRIMP PLUG (FOR RG-178B/U,196A/U) DRAWING NO. KJ-MMCX1112A1-012-3GT30G-50 ITEM NO. 091112AAL16GE5F				
5	COVER	NOTE 2	NOTE 3	1	CV-29X05-T		APPROVED					DATE	10-24-02'
4	RETAINER RING	NOTE 4	NOTE 3	1	MMCX1112A1-5-D		CHECKED					DATE	10-24-02'
3	CONTACT PIN	NOTE 1	NOTE 5	1	MMCX1112A1-4-B		DRAWN					DATE	10-24-02'
2	INSULATOR	NOTE 5	NATURAL	1	MMCX1112A1-3T-50-B		APPROVED					DATE	10-24-02'
1	HOUSING WITH BODY	NOTE 1	NOTE 3	1	MMCX1112A1-1S-17/1-B		DRAWN					DATE	10-24-02'

Amphenol - Kai Jack

TAINAN TAIWAN

TITLE MMCX R/A CRIMP PLUG
(FOR RG-178B/U,196A/U)

DRAWING NO. KJ-MMCX1112A1-012-3GT30G-50

ITEM NO. 091112AAL16GE5F

APPROVED *gacky* DATE 10-24-02'
 CHECKED *Ken* DATE 10-24-02'
 DRAWN *KEN* DATE 10-24-02'