

REVISIONS		
ISS	ZONE	DESCRIPTION\PER REQUEST\DATE
F	A-1	NO.4 WAS CHANGED\RD-DM90111901K\11-19-01'
		ADDED NO.5\RD-DM91121901K\12-19-02'

**SALES**

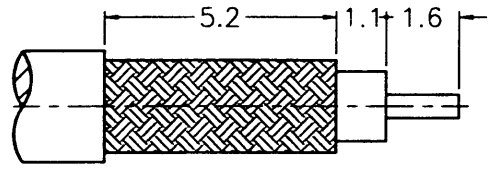

RECOMMENDED  
CABLE STRIPPING DIM'S  
(建議剝線尺寸)

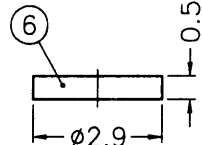
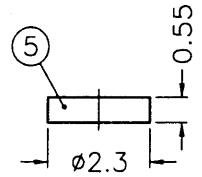
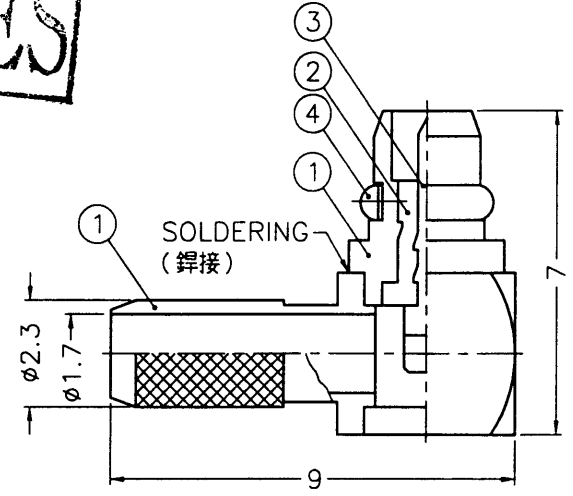
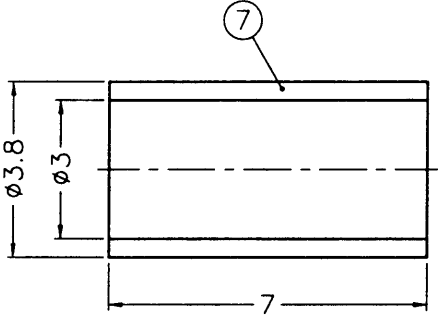

ISSUED  
2002.12.26  
R&D

1. CRIMPED FERRULE  
HEX. CRIMP SIZE .128"
2. CONTACT PIN TO SOLDER

NOTES: FINISH (PLATING THICKNESS IN MICRO-INCHES)  
 1. BRASS PER QQ-B-626  
 2. BRASS PER QQ-B-613  
 3. GOLD PL 3 MIN. THICK OVER NICKEL PL. 100 MIN. THICK OVER COPPER STRIKE  
 4. BERYLLIUM COPPER PER QQ-C-530  
 5. GOLD PL 30 MIN. THICK OVER NICKEL PL. 100 MIN. THICK OVER COPPER STRIKE  
 6. TEFLON MIL-P-19468

NO.	DESCRIPTION	MATERIAL	FINISH	Q'TY	DRAWING NO.
7	FERRULE	COPPER	NOTE 3	1	FR-38/3X7C
6	COVER	NOTE 2	NOTE 3	1	CV-29X05-T
5	INSULATOR	NOTE 6	NATURAL	1	MMCX1112A1-004-6T-B
4	RETAINER RING	NOTE 4	NOTE 3	1	MMCX1112A1-5-D
3	CONTACT PIN	NOTE 1	NOTE 5	1	MMCX1112A1-4-B
2	INSULATOR	NOTE 6	NATURAL	1	MMCX1112A1-3T-50-B
1	HOUSING WITH BODY	NOTE 1	NOTE 3	1	MMCX1112A1-1S-23/17-B

DIMENSIONS ARE IN MILLIMETERS				PART NO.	
UNLESS OTHERWISE SPECIFIED TOLERANCES				APPROVED	DATE
0.5-6	= ±0.2			<i>gackey</i>	12-25-02'
6-30	= ±0.4			<i>Ken</i>	12-25-02'
30-120	= ±0.6			<i>Ken</i>	12-25-02'
120-315	= ±1				
315-1000	= ±1.6				
1000-2000	= ±2.4				
SCALE	6/1	ISSUE	F	FILE NO.	F:\DWG\MMCX\1112A1\316U-50\3GT30G

Amphenol	
Danbury, CT, USA - Tainan, Taiwan - Shenzhen, China	
TITLE	MMCX R/A CRIMP PLUG (FOR RG-174/U, 188A/U, 316/U)
DRAWING NO.	MMCX1112A1-3GT30G-316U-50
ITEM NO.	091112AAB36GE5F

RD-DR 16585 8