

1 2 3 4 5 6 7 8

REVISIONS			
ISS	ZONE	DESCRIPTION	PER REQUEST\DATE
B	A-1	NO.1, NO.2 AND NO.4 WERE CHANGED\ RD-DM91070801H\07-08-02'	

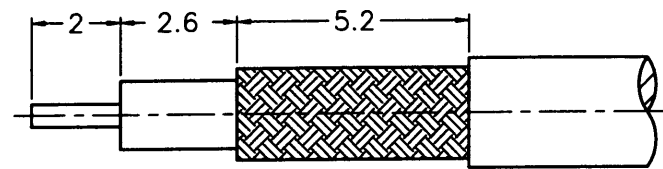

RECOMMENDED
CABLE STRIPPING DIM'S
(建議剝線尺寸)

SALES

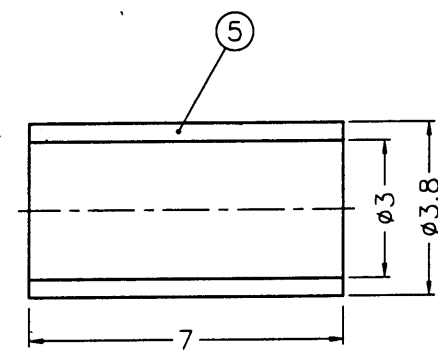
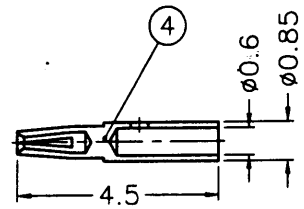
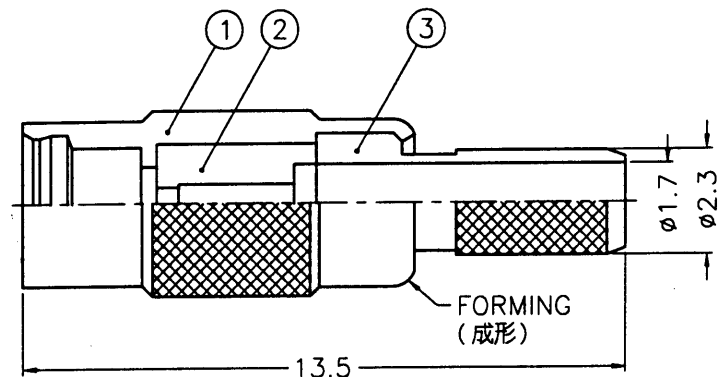

- NOTES: FINISH (PLATING THICKNESS IN MICRO-INCHES)
- BRASS PER QQ-B-626
 - GOLD PL. 3 MIN. THICK OVER NICKEL PL. 100 MIN. THICK OVER COPPER STRIKE
 - BERYLLIUM COPPER PER QQ-C-530
 - GOLD PL. 30 MIN. THICK OVER NICKEL PL. 100 MIN. THICK OVER COPPER STRIKE
 - TEFLON MIL-P-19468



- CRIMPED FERRULE
HEX. CRIMP SIZE .128"
- CONTACT PIN TO SOLDER

NO.	DESCRIPTION	MATERIAL	FINISH	Q'TY	DRAWING NO.	SCALE	6/1	ISSUE	B	FILE NO.	F:\DWG\MMCX\6121A1\316U-50\3GT30G
5	FERRULE	COPPER	NOTE 2	1	FR-38/3X7C	DIMENSIONS ARE IN MILLIMETERS UNLESS OTHERWISE SPECIFIED TOLERANCES 0.5-6 = ±0.2 6-30 = ±0.4 30-120 = ±0.6 120-315 = ±1 315-1000 = ±1.6 1000-2000 = ±2.4				PART NO.	Amphenol - Kai Jack TAINAN TAIWAN TITLE MMCX CRIMP JACK (FOR RG-174/U,188A/U,316/U) DRAWING NO. KJ-MMCX6121A1-3GT30G-316U-50 ITEM NO. 096111AAA36GE5F
4	CONTACT PIN	NOTE 3	NOTE 4	1	MMCX6121A1-4-085/06-B		APPROVED	<i>Jacky</i>	DATE	07-08-02'	
3	BARREL	NOTE 1	NOTE 2	1	MMCX1121A1-3-23/17		CHECKED	<i>Ken</i>	DATE	07-08-02'	
2	INSULATOR	NOTE 5	NATURAL	1	MMCX6121A1-2T-316U-B		DRAWN	<i>Ken</i>	DATE	07-08-02'	
1	BODY	NOTE 1	NOTE 2	1	MMCX6121A1-1-B						

7RD-DR/149>18

1 2 3 4 5 6