

REVISIONS		
ISS	ZONE	DESCRIPTION\PER REQUEST\DATE

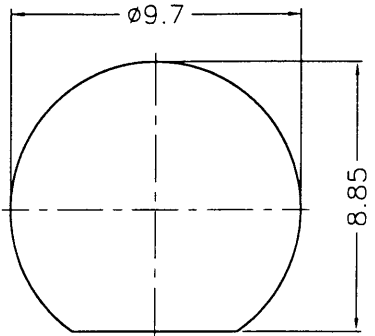

此改訂

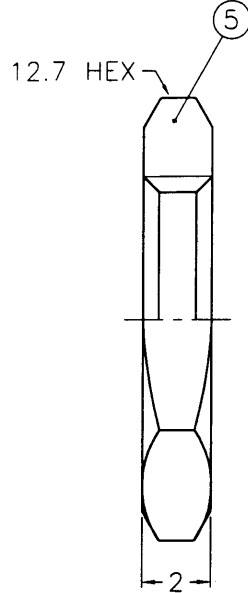
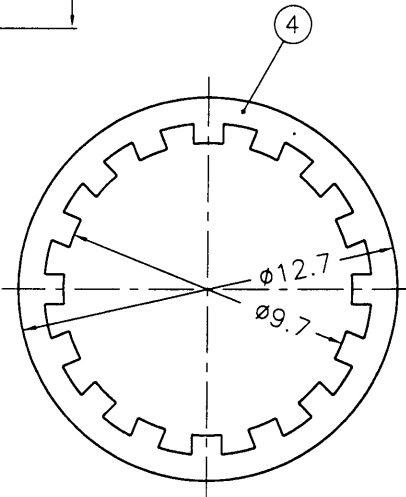
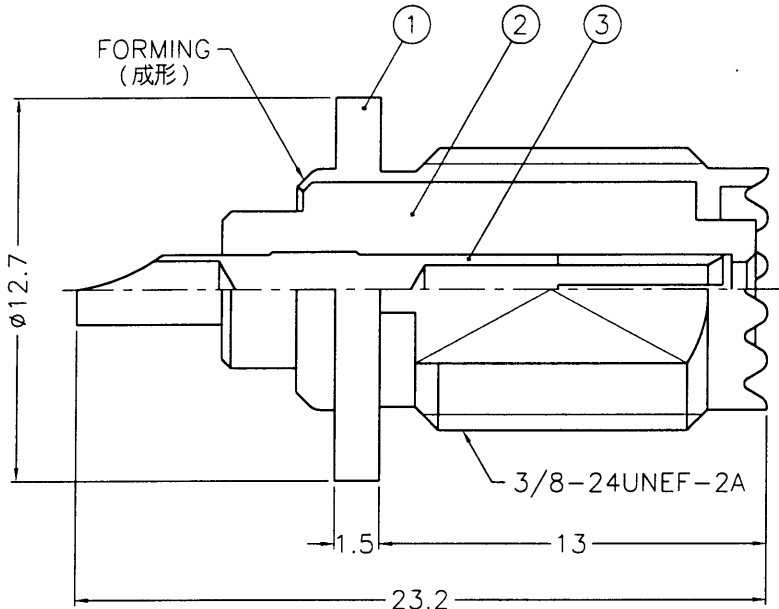

- NOTES: FINISH (PLATING THICKNESS IN MICRO-INCHES)
- BRASS PER QQ-B-626
  - BRASS PER QQ-B-613
  - NICKEL PL. 100 MIN. THICK OVER COPPER STRIKE
  - PHOSPHOR BRONZE PER QQ-B-750
  - GOLD PL. 3 MIN. THICK OVER NICKEL PL. 100 MIN. THICK OVER COPPER STRIKE
  - TEFLON MIL-P-19468

4/12  
88.5.12  
& D

DIMENSIONS ARE IN MILLIMETERS		PART NO.		
UNLESS OTHERWISE SPECIFIED TOLERANCES		APPROVED	DATE	
0.5-6 = ±0.2			05-11-99'	
6-30 = ±0.4			CHECKED	
30-120 = ±0.6			05-11-99'	
120-315 = ±1			DRAWN	DATE
315-1000 = ±1.6			05-11-99'	
1000-2000 = ±2.4			SCALE	4/1 ISSUE A
TITLE				MINI-UHF BULKHEAD RECEPT. JACK
DRAWING NO.				KJ-MU6451B1-NT3G-50
FILE NO.				F:\DWG\MU\6451B1\50\NT3G

NO.	DESCRIPTION	MATERIAL	FINISH	Q'TY	DRAWING NO.
5	HEX NUT	NOTE 1	NOTE 3	1	HN127-3/8-24X2
4	LOCK WASHER	NOTE 2	NOTE 3	1	LW-127/97X05
3	CONTACT PIN	NOTE 4	NOTE 5	1	MU7530-3T
2	INSULATOR	NOTE 6	NATURAL	1	MU7531-2T-50
1	BODY	NOTE 1	NOTE 3	1	MU7531-1