

1 2 3 4 5 6 7 8

REVISIONS		
ISS	ZONE	DESCRIPTION\PER REQUEST\DATE
A1	B-7	ADDED CRIMP TOOLS\N/A\11-18-00'
B	B-1	NO.9 WAS CHANGED\RD-DM90032701\03-27-01'

業務部

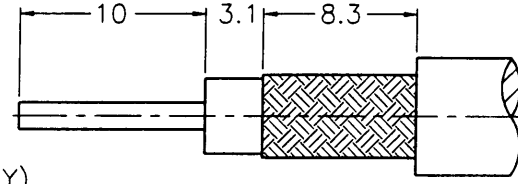
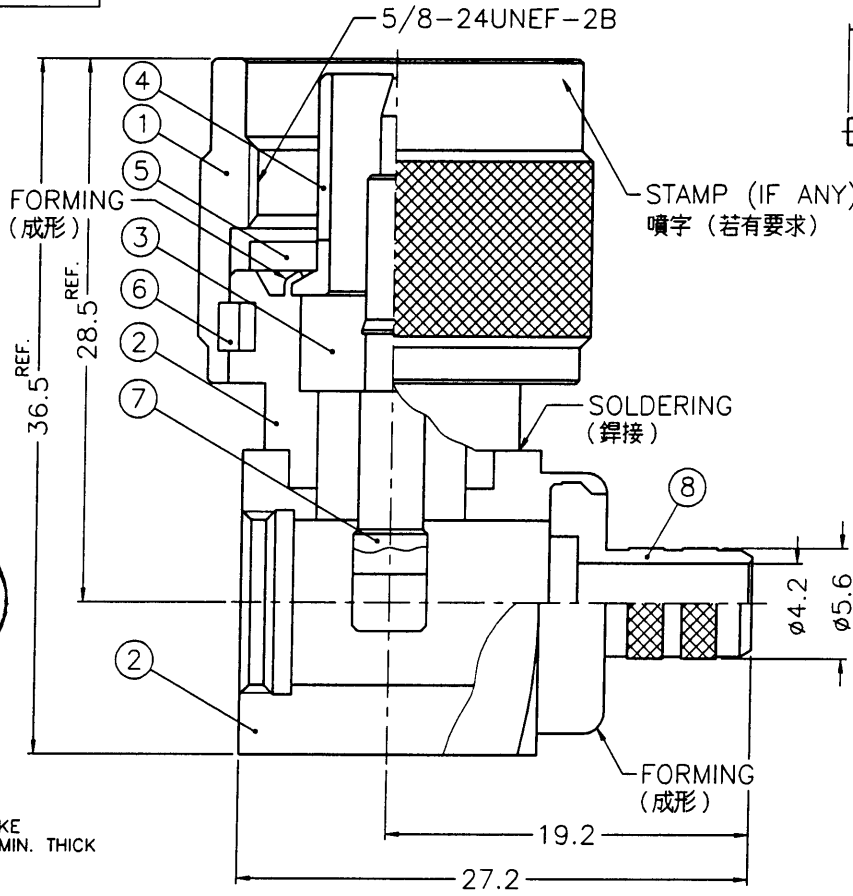

RECOMMENDED  
CABLE STRIPPING DIM'S  
(建議剝線尺寸)

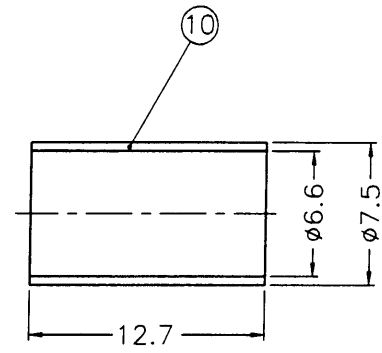

1. CRIMPED FERRULE  
HEX CRIMP SIZE .255"  
2. CONTACT PIN TO SOLDER

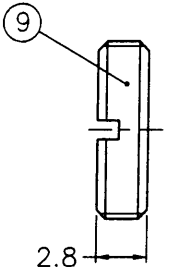

出圖  
2001. 4. 03  
設計部

NOTES: FINISH (PLATING THICKNESS IN MICRO-INCHES)  
1. BRASS PER QQ-B-626  
2. NICKEL PL. 100 MIN. THICK OVER COPPER STRIKE  
3. GOLD PL. 3 MIN. THICK OVER NICKEL PL. 100 MIN. THICK OVER COPPER STRIKE  
4. TEFLON MIL-P-19468  
5. JIS H 3250, C 2700

10	FERRULE	NOTE 5	NOTE 2	1	FR-75/66X127
9	NUT	NOTE 1	NOTE 2	1	B5291-14-28
8	BARREL	NOTE 1	NOTE 2	1	N5000-3-56/42
7	CONTACT PIN	NOTE 1	NOTE 3	1	N1112A1-7
6	RETAINER RING	SUS 304	NATURAL	1	N5000-7-C
5	GASKET	SILICONE	RED	1	GS-156/8X15
4	CONTACT BODY	NOTE 1	NOTE 2	1	N5000-5
3	INSULATOR	NOTE 4	NATURAL	1	N7995-2T-50
2	HOUSING WITH BODY	NOTE 1	NOTE 2	1	N1112A1-2S
1	SHELL	NOTE 1	NOTE 2	1	N5000-1-B
NO.	DESCRIPTION	MATERIAL	FINISH	Q'TY	DRAWING NO.

DIMENSIONS ARE IN MILLIMETERS  
UNLESS OTHERWISE SPECIFIED TOLERANCES  
0.5-6 = ±0.2  
6-30 = ±0.4  
30-120 = ±0.6  
120-315 = ±1  
315-1000 = ±1.6  
1000-2000 = ±2.4

PART NO.	
APPROVED	DATE 03-27-01'
CHECKED	DATE 03-27-01'
DRAWN	DATE 03-27-01'

Amphenol - Kai Jack	
TAINAN TAIWAN	
TITLE	N R/A CRIMP PLUG
DRAWING NO.	KJ-N1112A1-NT3G-8X-50
FILE NO.	F:\DWG\N\1112A1\8X-50\NT3G

RDBDR11933

1 2 3 4 5 6 7 8