

ISS	ZONE	DESCRIPTION\PER REQUEST\DATE
B	B-1	NO.9 WAS CHANGED\RD-DM900327011\03-27-01'

業務部

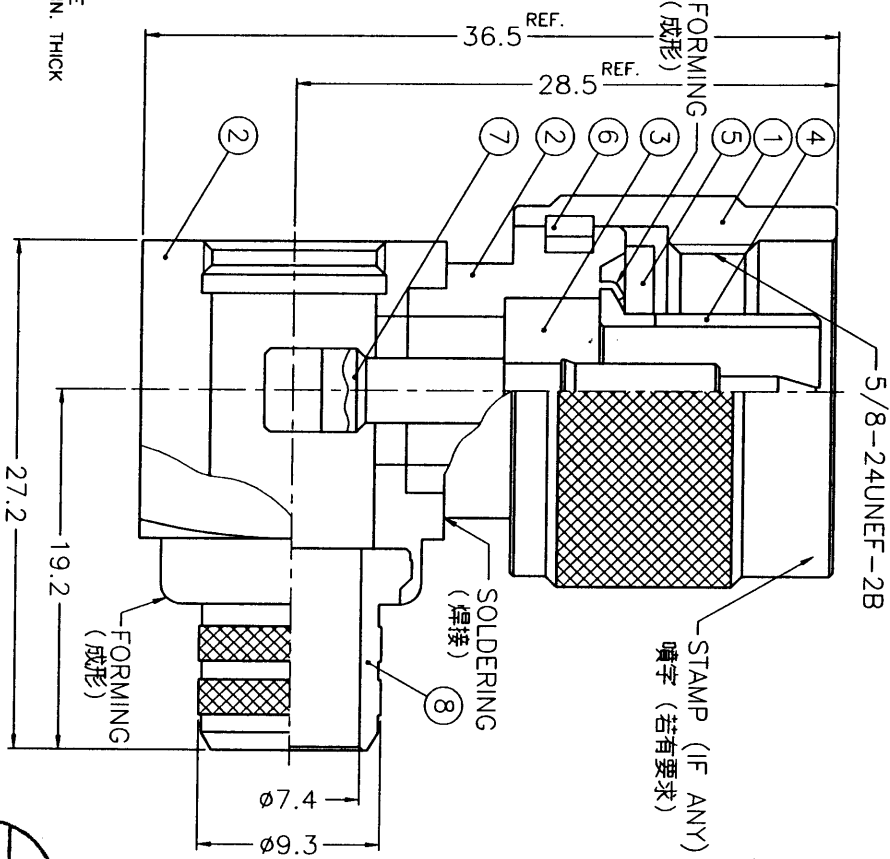

NOTES: FINISH (PLATING THICKNESS IN MICRO-INCHES)
 1. BRASS PER QQ-B-626
 2. NICKEL PL. 100 MIN. THICK OVER COPPER STRIKE
 3. GOLD PL. 3 MIN. THICK OVER NICKEL PL. 100 MIN. THICK OVER COPPER STRIKE
 4. TEFLON MIL-P-19468
 5. JIS H 3250, C 2700

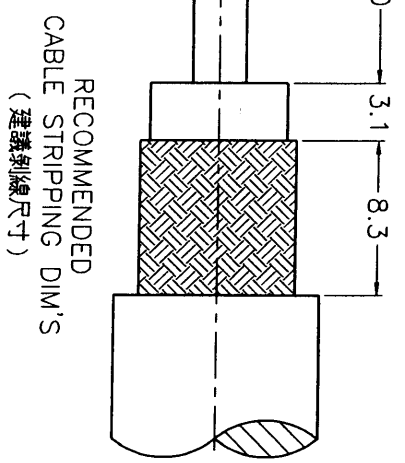
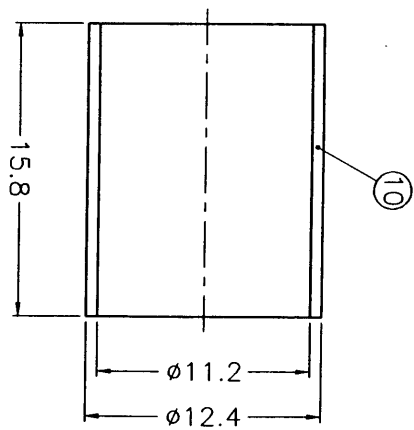
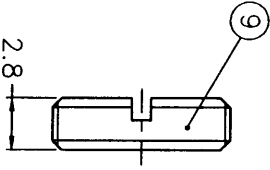

出圖
2001.4.03
設計部

1. CRIMPED FERRULE
 HEX CRIMP SIZE .429"
 2. CONTACT PIN TO SOLDER

NO.	DESCRIPTION	MATERIAL	FINISH	Q'TY	DRAWING NO.
10	FERRULE	NOTE 5	NOTE 2	1	FR-124/112X158
9	NUT	NOTE 1	NOTE 2	1	B5291-14-28
8	BARREL	NOTE 1	NOTE 2	1	N5000-3-93/74
7	CONTACT PIN	NOTE 1	NOTE 3	1	N1112A1-7-9913
6	RETAINER RING	SUS 304	NATURAL	1	N5000-7-C
5	GASKET	SILICONE	RED	1	GS-156/8X15
4	CONTACT BODY	NOTE 1	NOTE 2	1	N5000-5
3	INSULATOR	NOTE 4	NATURAL	1	N7995-2T-50
2	HOUSING WITH BODY	NOTE 1	NOTE 2	1	N1112A1-2S
1	SHELL	NOTE 1	NOTE 2	1	N5000-1-B

DIMENSIONS ARE IN MILLIMETERS
 UNLESS OTHERWISE SPECIFIED
 TOLERANCES
 0.5-6 = ±0.2
 6-30 = ±0.4
 30-120 = ±0.6
 120-315 = ±1
 315-1000 = ±1.6
 1000-2000 = ±2.4

PART NO.
 APPROVED DATE 03-27-01'
 CHECKED DATE 03-27-01'
 DRAWN DATE 03-27-01'

TITLE
Amphenol - Kai Jack
 TAINAN TAIWAN

N R/A CRIMP PLUG
 (FOR BELDEN 8214, 9913, 9914)
 DRAWING NO. KJ-N1112A6-NT3G-9913-50
 FILE NO. F:\DWG\N\1112A6\9913-50\NT3G

REVISIONS
 1 2 3 4 5 6 7 8
 A B C D E F
 1 2 3 4 5 6 7
 RD8BR1934