

| REVISIONS | | |
|-----------|------|------------------------------|
| ISS | ZONE | DESCRIPTION\PER REQUEST\DATE |
| | | |

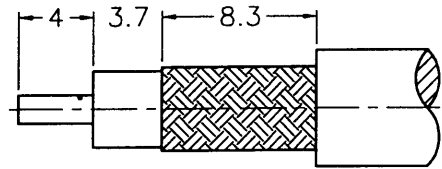

RECOMMENDED
CABLE STRIPPING DIM'S
(建議剝線尺寸)

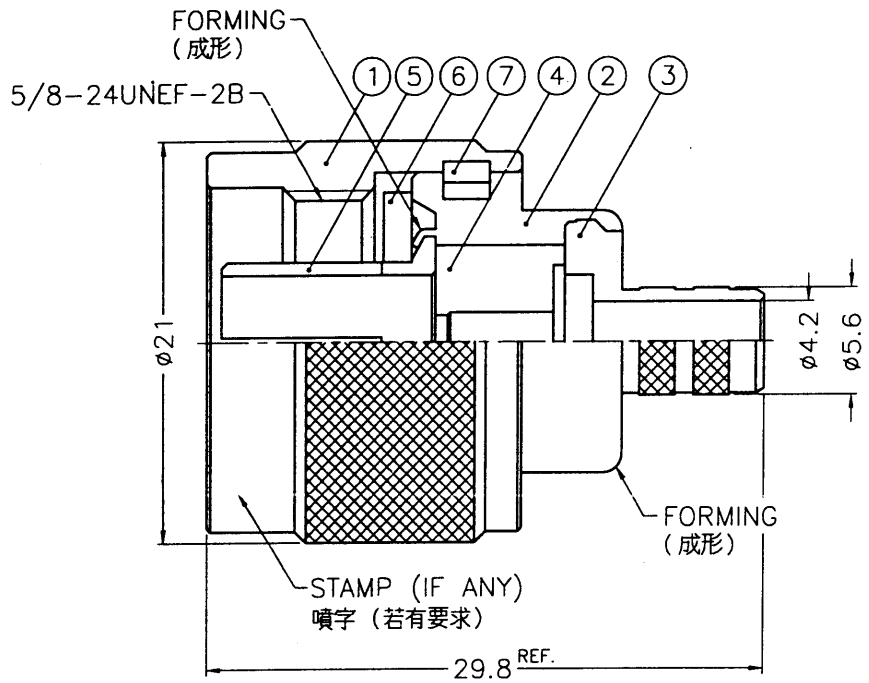
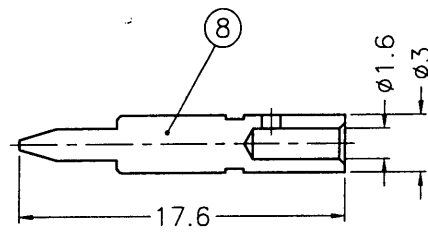

SALES

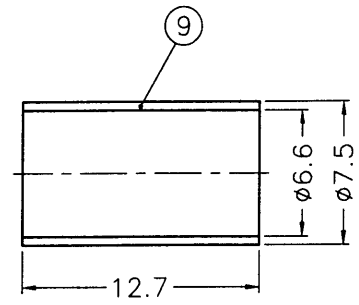

ISSUED
2002. 2. 22
&D

NOTES: FINISH (PLATING THICKNESS IN MICRO-INCHES)
 1. BRASS PER QQ-B-626
 2. ALBALOY PLATING (COPPER-TIN-ZINC) PL. 80 MIN. THICK
 3. GOLD PL. 30 MIN. THICK OVER COPPER PL. 100 MIN. THICK
 4. TEFLON MIL-P-19468
 5. JIS H 3250, C 2600

1. CRIMPED FERRULE
HEX. CRIMP SIZE .255"
 2. CRIMPED CONTACT PIN
HEX. CRIMP SIZE .100"

| NO. | DESCRIPTION | MATERIAL | FINISH | Q'TY | DRAWING NO. |
|-----|---------------|----------|---------|------|----------------|
| 9 | FERRULE | NOTE 5 | NATURAL | 1 | FR-75/66X127 |
| 8 | CONTACT PIN | NOTE 1 | NATURAL | 1 | N5000-8-3/16-B |
| 7 | RETAINER RING | SUS 304 | NATURAL | 1 | N5000-7-C |
| 6 | GASKET | SILICONE | RED | 1 | GS-156/8X15 |
| 5 | CONTACT BODY | NOTE 1 | NATURAL | 1 | N5000-5 |
| 4 | INSULATOR | NOTE 4 | NATURAL | 1 | N5000-4T-50-A |
| 3 | BARREL | NOTE 1 | NATURAL | 1 | N5000-3-56/42 |
| 2 | BODY | NOTE 1 | NATURAL | 1 | N5000-2 |
| 1 | SHELL | NOTE 1 | NATURAL | 1 | N5000-1-B |

| DIMENSIONS ARE IN MILLIMETERS | | | | PART NO. | |
|--|-------|-------|---|----------|------------------------------|
| UNLESS OTHERWISE SPECIFIED TOLERANCES 0.5-6 = ±0.2 6-30 = ±0.4 30-120 = ±0.6 120-315 = ±1 315-1000 = ±1.6 1000-2000 = ±2.4 | | | | APPROVED | DATE |
| | | | | CHECKED | DATE |
| | | | | DRAWN | DATE |
| SCALE | 2.5/1 | ISSUE | A | FILE NO. | F:\DWG\N\1121A1\8X-50\AT30GA |

| | |
|---|---------------------------------------|
| Amphenol - Kai Jack TAINAN TAIWAN | |
| TITLE | N CRIMP PLUG (FOR LMR-240, RG-8/X) |
| DRAWING NO. | KJ-N1121A1-AT30GA-8X-50 |
| ITEM NO. | 031121AAA89AG5F |

7RD-DR 13860 8