

1 2 3 4 5 6 7 8

REVISIONS		
ISS	ZONE	DESCRIPTION \ APPROVED \ DATE

業務部

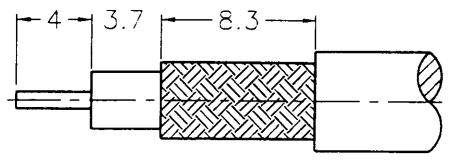

RECOMMENDED
CABLE STRIPPING DIM'S

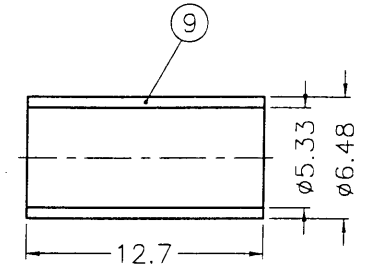
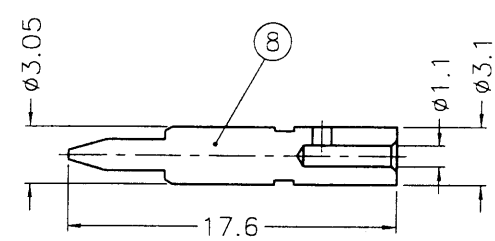
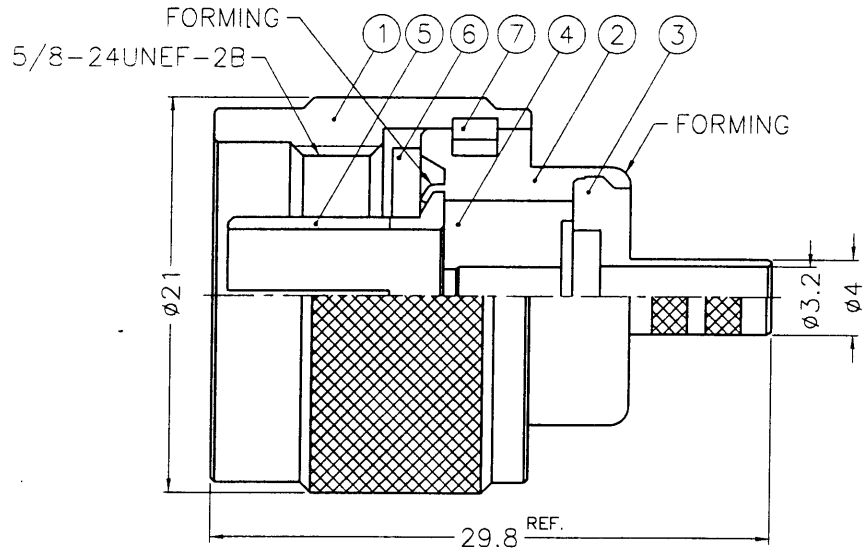

NOTES: FINISH (PLATING THICKNESS IN MICRO-INCHES)
 1. BRASS PER QQ-B-626
 2. NICKEL PL. 100 MIN. THICK OVER COPPER STRIKE
 3. GOLD PL. 3 MIN. THICK OVER NICKEL PL. 100 MIN. THICK OVER COPPER STRIKE
 4. TEFLON MIL-P-19468

出圖
87.7.28
R&D

9	FERRULE	COPPER	NOTE 2	1	FR-648/533X 127C
8	CONTACT PIN	NOTE 1	NOTE 3	1	N5000-8-31/11 -C
7	RETAINER RING	SUS 304	NATURAL	1	N5000-7-C
6	GASKET	SILICONE	RED	1	GS-156/8X15
5	CONTACT BODY	NOTE 1	NOTE 2	1	N5000-5
4	INSULATOR	NOTE 4	NATURAL	1	RF10028-001-4
3	BARREL	NOTE 1	NOTE 2	1	N5000-3-4/32
2	BODY	NOTE 1	NOTE 2	1	N5000-2
1	SHELL	NOTE 1	NOTE 2	1	N5000-1-B
NO.	DESCRIPTION	MATERIAL	FINISH	Q'TY	DRAWING NO.

DIMENSIONS ARE IN MILLIMETERS
 UNLESS OTHERWISE SPECIFIED TOLERANCES
 0.5-6 = ±0.2
 6-30 = ±0.4
 30-120 = ±0.6
 120-315 = ±1
 315-1000 = ±1.6
 1000-2000 = ±2.4

PART NO.	
APPROVED	DATE
CHECKED	DATE
DRAWN	DATE

KAI JACK INDUSTRIAL CO., LTD. TAINAN TAIWAN R.O.C.	
TITLE	
N CRIMP PLUG	
DRAWING NO.	
KJ-N1121A1-NT3G-142AU-50	
FILE NO.	
F:\DWG\N\1121A1\142AU-50\NT3G	

1 2 3 4 5 6 7 8

8N-R1356