

REVISIONS		
ISS	ZONE	DESCRIPTION \ APPROVED \ DATE

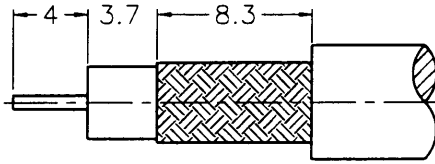

RECOMMENDED  
CABLE STRIPPING DIM'S

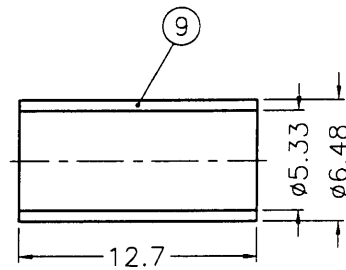
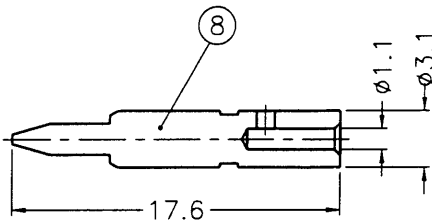
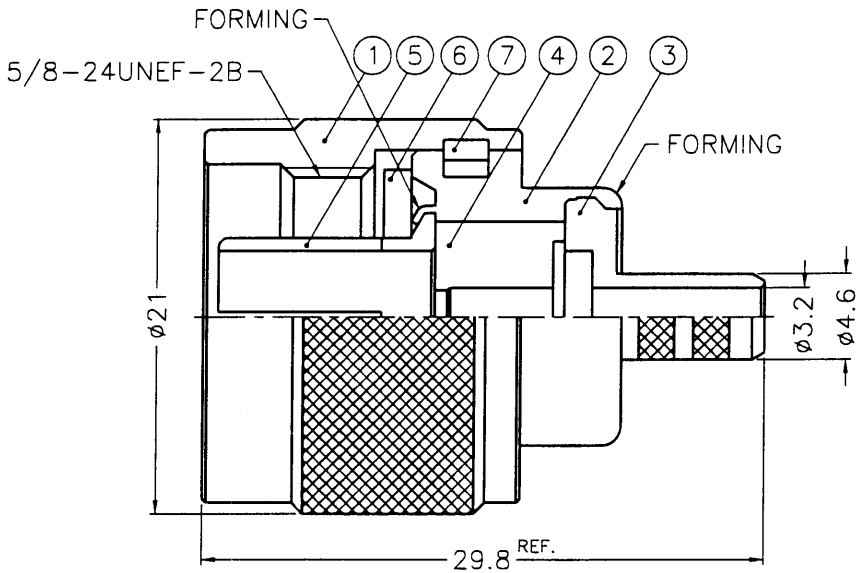

- NOTES: FINISH (PLATING THICKNESS IN MICRO-INCHES)
- BRASS PER QQ-B-626
  - NICKEL PL. 100 MIN. THICK OVER COPPER STRIKE
  - GOLD PL. 3 MIN. THICK OVER NICKEL PL. 100 MIN. THICK OVER COPPER STRIKE
  - TEFLON MIL-P-19468

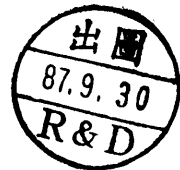

9	FERRULE	COPPER	NOTE 2	1	FR-648/533X 127C
8	CONTACT PIN	NOTE 1	NOTE 3	1	N5000-8-31/11 -C
7	RETAINER RING	SUS 304	NATURAL	1	N5000-7-C
6	GASKET	SILICONE	RED	1	GS-156/BX15
5	CONTACT BODY	NOTE 1	NOTE 2	1	N5000-5
4	INSULATOR	NOTE 4	NATURAL	1	RF1002B-001-4
3	BARREL	NOTE 1	NOTE 2	1	N5000-3-46/32
2	BODY	NOTE 1	NOTE 2	1	N5000-2
1	SHELL	NOTE 1	NOTE 2	1	N5000-1-B
NO.	DESCRIPTION	MATERIAL	FINISH	Q'TY	DRAWING NO.

DIMENSIONS ARE IN MILLIMETERS			
UNLESS OTHERWISE SPECIFIED TOLERANCES			
0.5-6	=	±0.2	
6-30	=	±0.4	
30-120	=	±0.6	
120-315	=	±1	
315-1000	=	±1.6	
1000-2000	=	±2.4	
SCALE	2.5/1	ISSUE	A

PART NO.	
APPROVED	DATE 09-30-98'
CHECKED	DATE 09-30-98'
DRAWN	DATE 09-30-98'

<b>KAI JACK INDUSTRIAL CO., LTD.</b> TAINAN TAIWAN R.O.C.	
TITLE	N CRIMP PLUG
DRAWING NO.	KJ-N1121A1-NT3G-58CU-50
FILE NO.	F:\DWG\N\1121A1\58CU-50\NT3G

A

A