

REVISIONS	
ISS	ZONE
A	A-8
DESCRIPTION\PER REQUEST\DATE	
N1121A2-002-ST30GA-H243-50 WAS	
172102H243-ST30GA\N\A\03-01-02'	

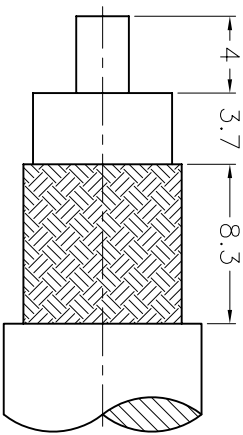

RECOMMENDED  
CABLE STRIPPING DIM'S  
(建議剝線尺寸)

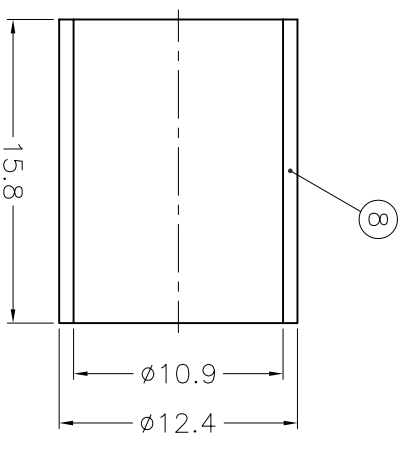
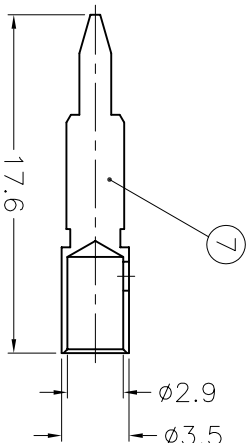
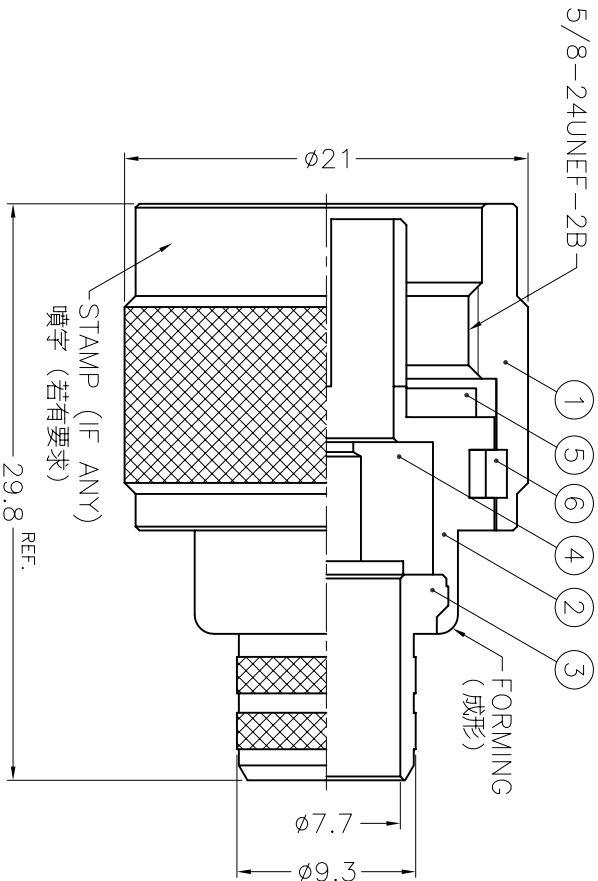

NOTES: FINISH (PLATING THICKNESS IN MICRO-INCHES)  
 1. BRASS PER QQ-B-626  
 2. SILVER PL. 80 MIN. THICK OVER COPPER STRIKE  
 3. GOLD PL. 30 MIN. THICK OVER COPPER PL. 100 MIN. THICK  
 4. TEFLON MIL-P-19468  
 5. JIS H 3250, C 2600

1. CRIMPED FERRULE  
 HEX. CRIMP SIZE .429"  
 2. CRIMPED CONTACT PIN  
 HEX. CRIMP SIZE .118"

NO.	DESCRIPTION	MATERIAL	FINISH	Q'TY	DRAWING NO.
8	FERRULE	NOTE 5	NOTE 2	1	FR-124/109X158
7	CONTACT PIN	NOTE 1	NOTE 3	1	NS201-11-35/29
6	RETAINER RING	SUS 304	NATURAL	1	NS000-7-C
5	GASKET	SILICONE	RED	1	GS-156/8X15
4	INSULATOR	NOTE 4	NATURAL	1	NS201-5T-50-9913
3	BARREL	NOTE 1	NOTE 2	1	NS000-3-93/77
2	BODY	NOTE 1	NOTE 2	1	N1121A2-2
1	SHELL	NOTE 1	NOTE 2	1	NS000-1-B

DIMENSIONS ARE IN MILLIMETERS  
 UNLESS OTHERWISE SPECIFIED  
 TOLERANCES

0.5-6 = ±0.2  
 6-30 = ±0.4  
 30-120 = ±0.6  
 120-315 = ±1  
 315-1000 = ±1.6  
 1000-2000 = ±2.4

PART NO.

APPROVED

CHECKED

DRAWN

DATE

DATE

DATE

TITLE

N CRIMP PLUG

TAINAN TAIWAN

**Amphenol - Kai Jack**

DRAWING NO.

KJ-N1121A2-002-ST30GA-H243-50

ITEM NO.

031121ABAA1SC5F

1 2 3 4 5 6 7 8

A

B

C

D

E

F

A

B

C

D

E

F