

1			2			3			4			5			6			7			8		
REVISIONS																							
ISS	ZONE	DESCRIPTION\PER REQUES\DATE																					

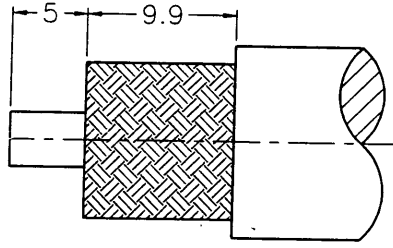

RECOMMENDED
CABLE STRIPPING DIM'S
(建議剝線尺寸)

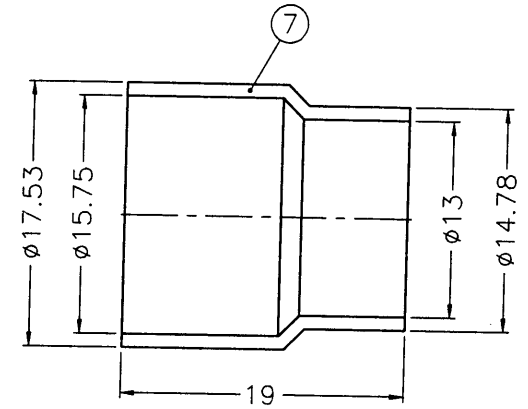
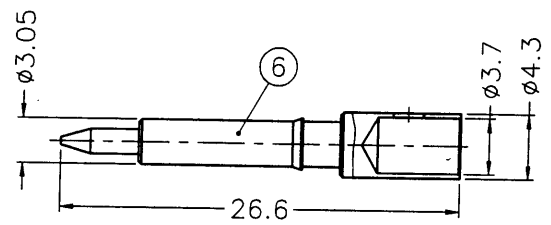
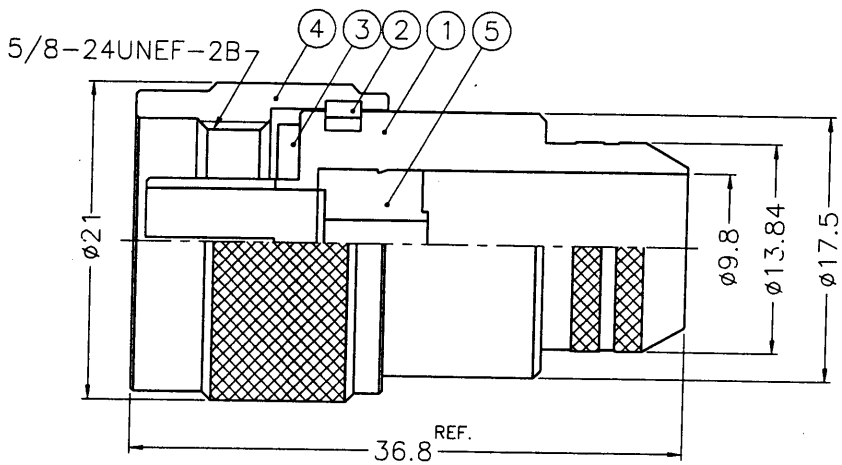

1. CRIMPED FERRULE
HEX CRIMP SIZE .6"

- NOTES: FINISH (PLATING THICKNESS IN MICRO-INCHES)
- BRASS PER QQ-B-626
 - NICKEL PL. 100 MIN. THICK OVER COPPER STRIKE
 - GOLD PL. 3 MIN. THICK OVER NICKEL PL. 100 MIN. THICK OVER COPPER STRIKE
 - TEFLON MIL-P-19468
 - JIS H 3260, C 3501



7	FERRULE	NOTE 5	NOTE 2	1	FR-1753/1575-1478/13X19
6	CONTACT PIN	NOTE 1	NOTE 3	1	N1121C5-6-43/37
5	INSULATOR	NOTE 4	NATURAL	1	N1121C5-5T-50
4	SHELL	NOTE 1	NOTE 2	1	N5000-1-B
3	GASKET	SILICONE	RED	1	GS-156/8X15
2	RETAINER RING	SUS 304	NATURAL	1	N5000-7-C
1	BODY	NOTE 1	NOTE 2	1	N1121C5-1-1384/98

DIMENSIONS ARE IN MILLIMETERS			
UNLESS OTHERWISE SPECIFIED TOLERANCES			
0.5-6	=	±0.2	
6-30	=	±0.4	
30-120	=	±0.6	
120-315	=	±1	
315-1000	=	±1.6	
1000-2000	=	±2.4	

PART NO.	
APPROVED	DATE
CHECKED	DATE
DRAWN	DATE

Amphenol - Kai Jack	
TAINAN TAIWAN	
TITLE N CRIMP PLUG (FOR FLEXIBLE LMR 500 CABLE)	
DRAWING NO. KJ-N1121C5-NT3G-LMR500-50	
FILE NO. F:\DWG\N\1121C5\L500-50\NT3G	

A