

REVISIONS			
ISS	ZONE	DESCRIPTION\PER REQUEST\DATE	
B	A-1	NO.2 WAS CHANGED\RD-DM87091101W\09-11-98'	
B1	B-6	LOGO WAS CHANGED\N/A\09-15-00'	
C	A-1	NO.1 AND NO.2 WERE CHANGED\RD-DM89092601Y\09-26-00'	

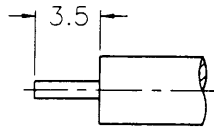

RECOMMENDED  
CABLE STRIPPING DIM'S  
(建議剥線尺寸)

業務部

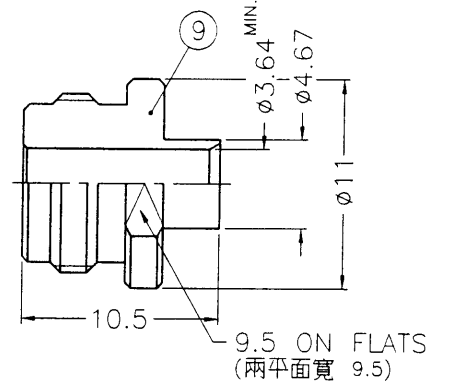
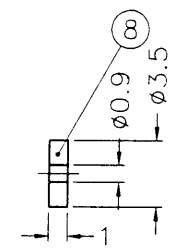
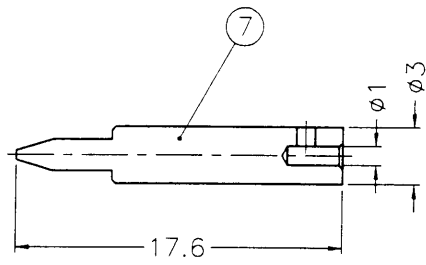
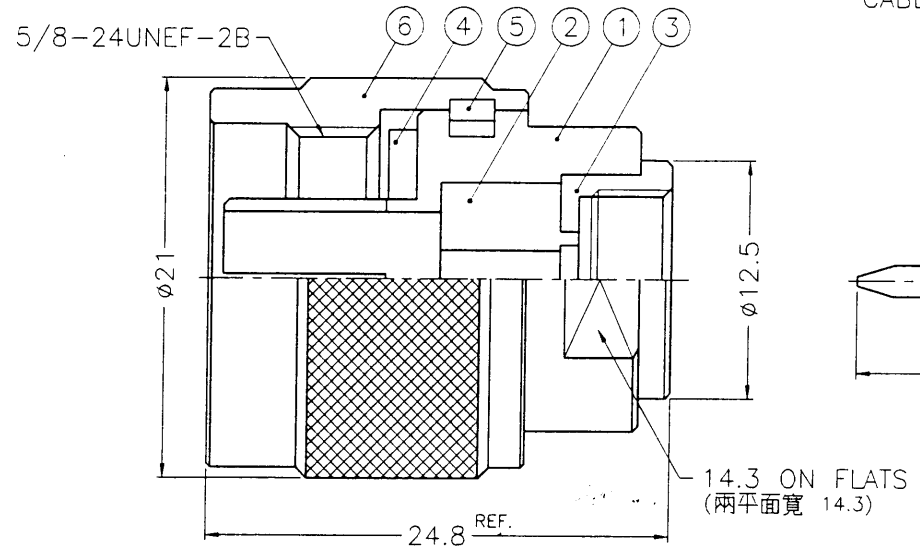

NOTES: FINISH (PLATING THICKNESS IN MICRO-INCHES)  
 1. BRASS PER QQ-B-626  
 2. NICKEL PL. 100 MIN. THICK OVER COPPER STRIKE  
 3. GOLD PL. 3 MIN. THICK OVER NICKEL PL. 100 MIN. THICK OVER COPPER STRIKE  
 4. TEFLON MIL-P-19468

2000.9.28  
設計部

1. CRIMPED CONTACT PIN  
HEX CRIMP SIZE .100"

9	SOLDER NUT	NOTE 1	NOTE 3	1	N6481A2-6-467/364
8	INSULATOR	NOTE 4	NATURAL	1	N6481A2-5T-35/09
7	CONTACT PIN	NOTE 1	NOTE 3	1	N1181B1-7-3/1
6	SHELL	NOTE 1	NOTE 2	1	N5000-1-B
5	RETAINER RING	SUS 304	NATURAL	1	N5000-7-C
4	GASKET	SILICONE	RED	1	GS-156/8X15
3	INNER BODY	NOTE 1	NOTE 2	1	N6481A2-3
2	INSULATOR	NOTE 4	NATURAL	1	N6481A2-2T-50-C
1	OUTER BODY	NOTE 1	NOTE 2	1	N1181B1-1-B
NO.	DESCRIPTION	MATERIAL	FINISH	Q'TY	DRAWING NO.

DIMENSIONS ARE IN MILLIMETERS				PART NO.	
UNLESS OTHERWISE SPECIFIED TOLERANCES				APPROVED	DATE
0.5-6	= ±0.2	6-30	= ±0.4	<i>Mark C</i>	09-26-00'
30-120	= ±0.6	120-315	= ±1	<i>Jarckey</i>	09-26-00'
315-1000	= ±1.6	1000-2000	= ±2.4	<i>Joyce</i>	09-26-00'
SCALE	2.5/1	ISSUE	C	DRAWN	DATE

Amphenol - Kai Jack	
TAINAN TAIWAN	
TITLE	N DIRECT SOLDER PLUG
DRAWING NO.	KJ-N1181B1-3G/NT3G-.141-50
FILE NO.	F:\DWG\N\1181B1\141-50\3GNT3G

F  
E  
D  
C  
B  
A

F  
E  
D  
C  
E  
A