

REVISIONS		
ISS	ZONE	DESCRIPTION\PER REQUEST\DATE

SALES

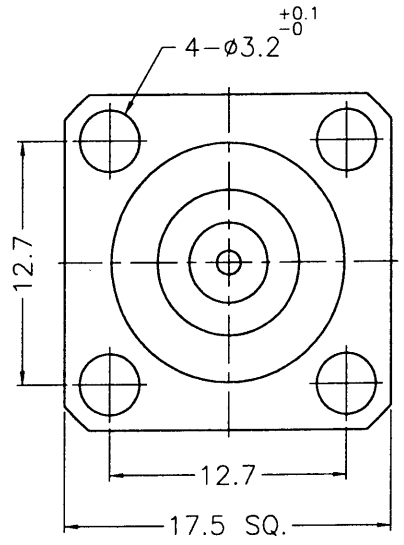
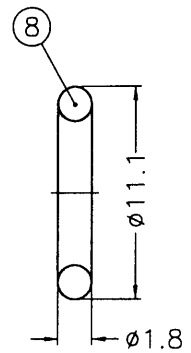
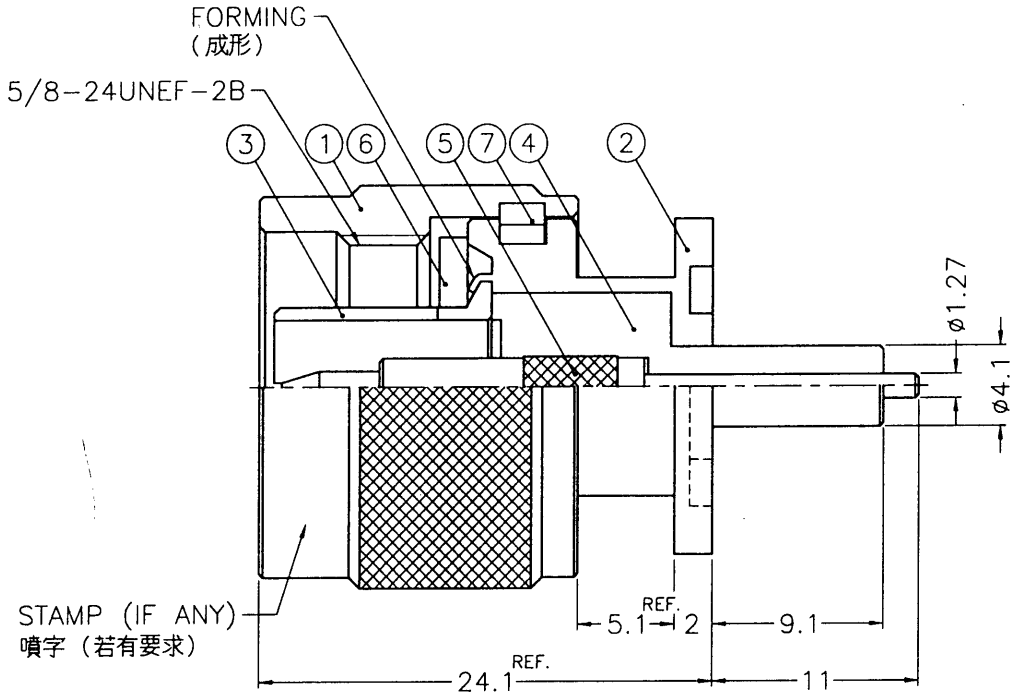

NOTES: FINISH (PLATING THICKNESS IN MICRO-INCHES)
 1. BRASS PER QQ-B-626
 2. NICKEL PL. 100 MIN. THICK OVER COPPER STRIKE
 3. GOLD PL. 3 MIN. THICK OVER NICKEL PL. 100 MIN. THICK OVER COPPER STRIKE
 4. TEFLON MIL-P-19468

ISSUED
 2003. 7. 11
 R & D

NO.	DESCRIPTION	MATERIAL	FINISH	Q'TY	DRAWING NO.
8	GASKET	SILICONE	RED	1	GS-111/75XD18-B
7	RETAINER RING	SUS 304	NATURAL	1	N5000-7-C
6	GASKET	SILICONE	RED	1	GS-156/8X15
5	CONTACT PIN	NOTE 1	NOTE 3	1	CP03ADC04A
4	INSULATOR	NOTE 4	NATURAL	1	NS00AMT04A
3	CONTACT BODY	NOTE 1	NOTE 2	1	N5000-5
2	BODY	NOTE 1	NOTE 2	1	BD00ADA02A
1	SHELL	NOTE 1	NOTE 2	1	N5000-1-B

DIMENSIONS ARE IN MILLIMETERS				PART NO.	
UNLESS OTHERWISE SPECIFIED TOLERANCES 0.5-6 = ±0.2 6-30 = ±0.4 30-120 = ±0.6 120-315 = ±1 315-1000 = ±1.6 1000-2000 = ±2.4				APPROVED	DATE
				CHECKED	DATE
				DRAWN	DATE
				FILE NO.	F:\DWG\N\1551E1\50\NT3G-A1

Amphenol	
Danbury,CT,USA-Tainan,Taiwan-Shenzhen,China	
TITLE	N PANEL RECEPT. PLUG
DRAWING NO.	N1551E1-NT3G-50
ITEM NO.	031551AAN02NA5F

A