

1 2 3 4 5 6 7 8

REVISIONS		
ISS	ZONE	DESCRIPTION\PER REQUEST\DATE

業務部

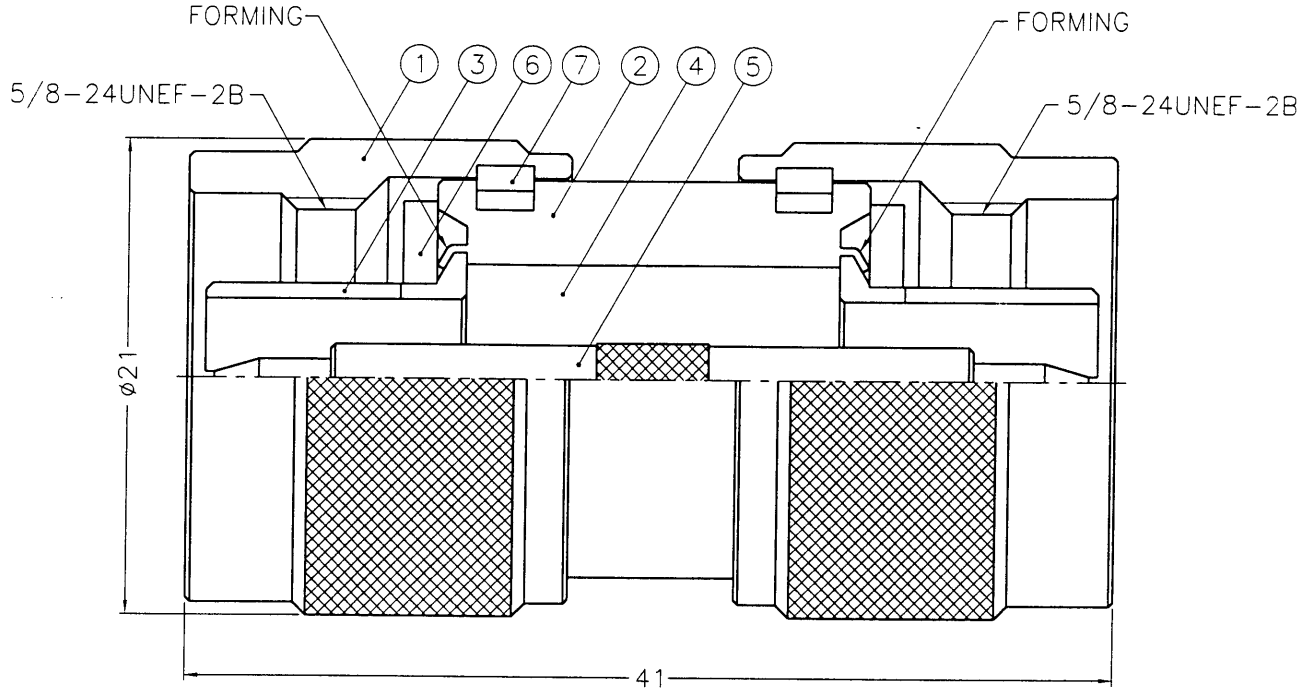

NOTES: FINISH (PLATING THICKNESS IN MICRO-INCHES)
 1. BRASS PER QQ-B-626
 2. NICKEL PL. 100 MIN. THICK OVER COPPER STRIKE
 3. GOLD PL. 3 MIN. THICK OVER NICKEL PL. 100 MIN. THICK OVER COPPER STRIKE
 4. TEFLON MIL-P-19468

88.3.04
R & D

DIMENSIONS ARE IN MILLIMETERS						PART NO.		KAI JACK INDUSTRIAL CO., LTD. TAINAN TAIWAN R.O.C.		
7	RETAINER RING	SUS 304	NATURAL	2	N5000-7-C	UNLESS OTHERWISE SPECIFIED TOLERANCES 0.5-6 = ±0.2 6-30 = ±0.4 30-120 = ±0.6 120-315 = ±1 315-1000 = ±1.6 1000-2000 = ±2.4		APPROVED	DATE	TITLE
6	GASKET	SILICONE	RED	2	GS-156/8X15			Mark.C	03-02-99'	N MALE TO MALE ADAPTOR
5	CONTACT PIN	NOTE 1	NOTE 3	1	N5900-5-B			CHECKED	DATE	DRAWING NO.
4	INSULATOR	NOTE 4	NATURAL	1	N5900-4T-50-A			Mark.C	03-02-99'	KJ-N2071A1-NT3G-50
3	CONTACT BODY	NOTE 1	NOTE 2	2	N5000-5			DRAWN	DATE	FILE NO.
2	BODY	NOTE 1	NOTE 2	1	N5900-2			Ada	03-02-99'	F:\DWG\N\2071A1\50\NT3G
1	SHELL	NOTE 1	NOTE 2	2	N5000-1-B					
NO.	DESCRIPTION	MATERIAL	FINISH	Q'TY	DRAWING NO.	SCALE	3/1	ISSUE	A	

172261 800TR4469