

1 2 3 4 5 6 7 8

REVISIONS			
ISS	ZONE	DESCRIPTION\PER REQUEST\DATE	

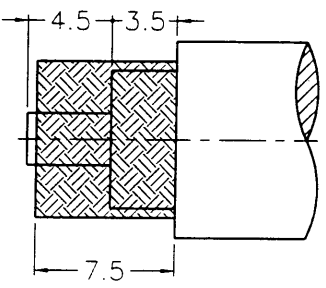

RECOMMENDED
CABLE STRIPPING DIM'S

業務部

F
E
D
C
B
A

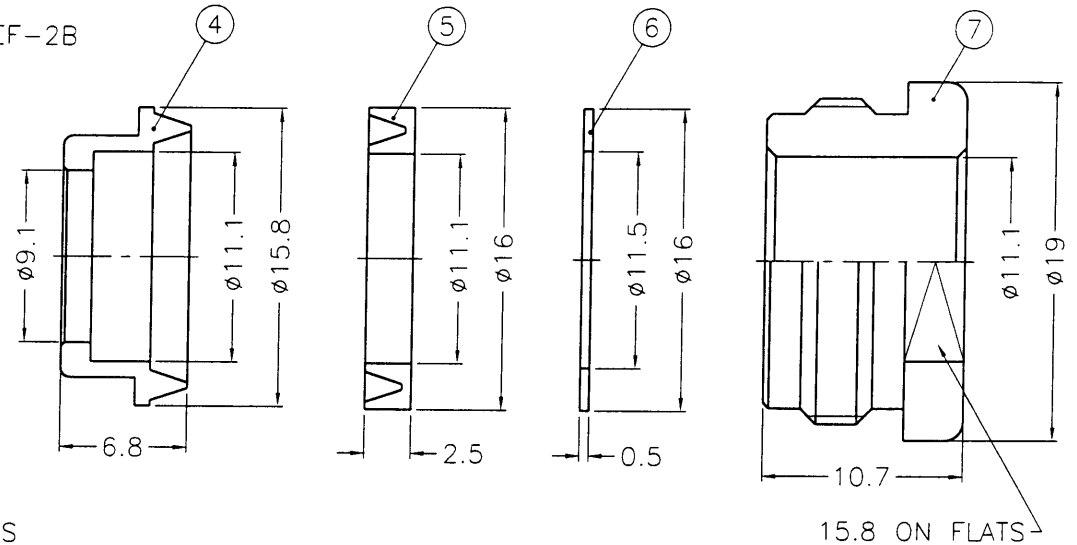
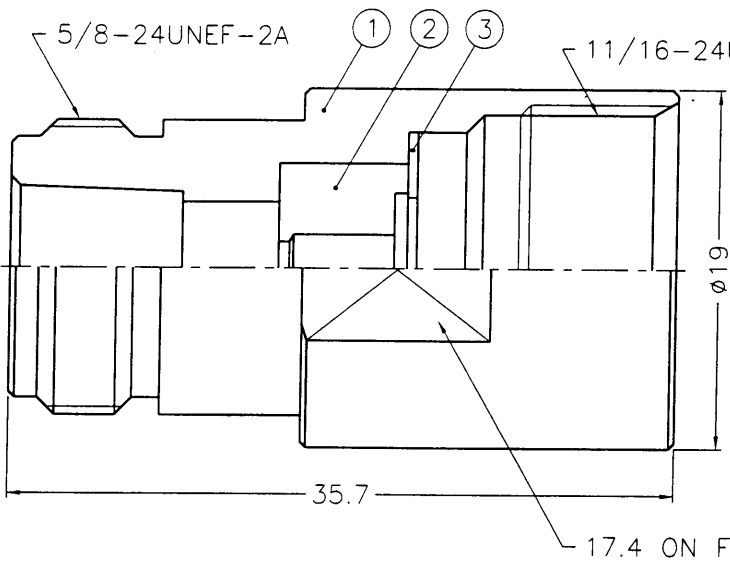

- NOTES: FINISH (PLATING THICKNESS IN MICRO-INCHES)
1. BRASS PER QQ-B-626
 2. BRASS PER QQ-B-613
 3. NICKEL PL. 100 MIN. THICK OVER COPPER STRIKE
 4. PHOSPHOR BRONZE PER QQ-B-750
 5. GOLD PL. 3 MIN. THICK OVER NICKEL PL. 100 MIN. THICK OVER COPPER STRIKE
 6. TEFLON MIL-P-19468

NO.	DESCRIPTION	MATERIAL	FINISH	Q'TY	DRAWING NO.
8	CONTACT PIN			1	N7000-4-35/29
7	NUT			1	B5201-12-19/111
6	WASHER			1	WS-16/115X05
5	GASKET	SILICONE	RED	1	B5201-10
4	BRAID CLAMP			1	B5201-9-111/91
3	WASHER			1	WS-145/75X05
2	INSULATOR		NATURAL	1	N5201-5T-50-9913
1	BODY			1	N7201-1-19/111

DIMENSIONS ARE IN MILLIMETERS
UNLESS OTHERWISE SPECIFIED TOLERANCES

0.5-6	= ±0.2
6-30	= ±0.4
30-120	= ±0.6
120-315	= ±1
315-1000	= ±1.6
1000-2000	= ±2.4

PART NO. _____

APPROVED *Mark C* DATE 01-13-99'

CHECKED *Mark C* DATE 01-13-99'

DRAWN *Ada* DATE 01-13-99'

KAI JACK INDUSTRIAL CO., LTD.
TAINAN TAIWAN R.O.C.

TITLE
N CLAMP JACK
(FOR BELDEN 9913, 9914)

DRAWING NO.
KJ-N6141A2-NT3G-9913-50

FILE NO. F:\DWG\N\6141A2\9913-50\NT3G

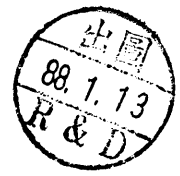

1120038N-R1489