

ISS	ZONE	DESCRIPTION \ APPROVED \ DATE
B	A-1	DRAWING NO. WERE CHANGED ON NO.3, NO.4, NO.5, NO.6, NO.7 AND NO.8 \ TONY. T\09-23-96'
	B-1	

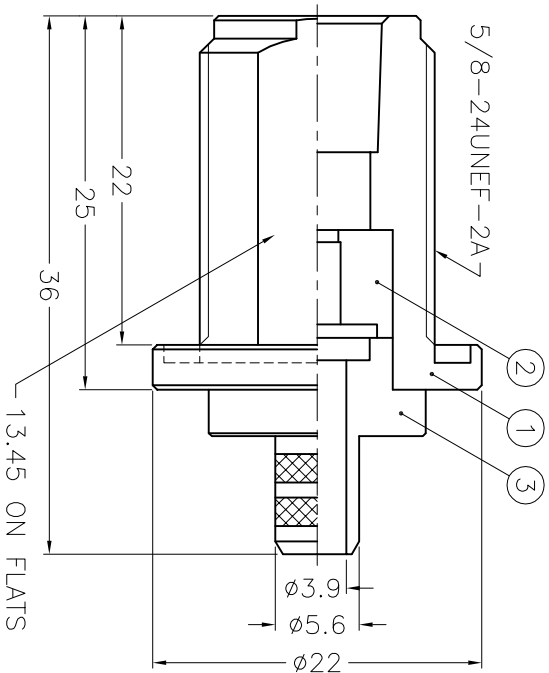
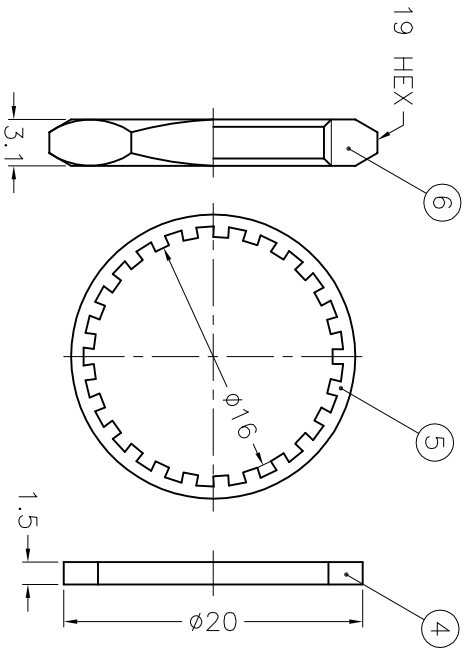
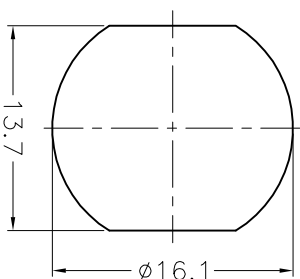
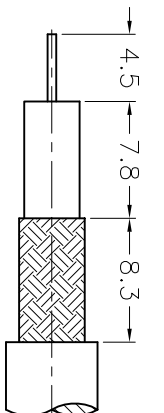

- NOTES: FINISH (PLATING THICKNESS IN MICRO-INCHES)
1. BRASS PER QQ-B-626, ALLOY 360, 1/2 H.
 2. BRASS PER QQ-B-613, COMP 260, HARD TEMP.
 3. NICKEL PL. 100 MIN. OVER COPPER PL. 50 MIN.
 4. SILVER PL. 80 MIN. OVER COPPER PL. 50 MIN.
 5. PHOSPHOR BRONZE PER QQ-B-750, COMP A, 1/2 H.
 6. GOLD PL. MIN. OVER NICKEL PL. 50 MIN.
 7. OVER COPPER PL. 50 MIN.
 8. SILVER PL. 100 MIN. OVER COPPER PL. 50 MIN.
 9. OVER COPPER PL. 50 MIN.
 10. TEFLON MIL-P-19468

NO.	DESCRIPTION	MATERIAL	FINISH	Q'TY	DRAWING NO.
8	FERRULE	NOTE 1	NOTE 3	1	FR-75/66X127
7	CONTACT PIN	NOTE 4	NOTE 5	1	N7000-4-3/076
6	HEX NUT	NOTE 1	NOTE 3	1	HN19-5/8-24X31
5	LOCK WASHER	NOTE 2	NOTE 3	1	LW-19/16X06
4	GASKET	SILICONE	RED	1	GS-20/16X15
3	BARREL	NOTE 1	NOTE 3	1	N7400-3-56/39
2	INSULATOR	NOTE 6	NATURAL	1	N5000-4T-50-A
1	BODY	NOTE 1	NOTE 3	1	N7400-1

DIMENSIONS ARE IN MILLIMETERS	
UNLESS OTHERWISE SPECIFIED	TOLERANCES
0.5-6	= ±0.2
6-30	= ±0.4
30-120	= ±0.6
120-315	= ±1
315-1000	= ±1.6
1000-2000	= ±2.4

PART NO.	APPROVED	DATE
		09-23-96'
CHECKED	CHECKED	DATE
		09-23-96'
DRAWN	DRAWN	DATE
		09-23-96'

TITLE	DRAWING NO.	FILE NO.
N BULKHEAD CRIMP JACK	KJ-N6421A1-59U-50	F:\DWG\N6421A1\59U-50



KAI JACK INDUSTRIAL CO., LTD.
TAINAN TAIWAN R.O.C.

A

B

C

D

E

F

1

2

3

4

5

6

7

8

A

B

C

D

E

F