

1 2 3 4 5 6 7 8

REVISIONS		
ISS	ZONE	DESCRIPTION\PER REQUEST\DATE

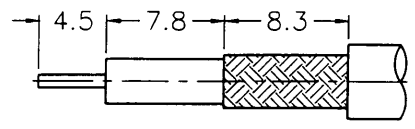

RECOMMENDED
CABLE STRIPPING DIM'S
(建議剝線尺寸)

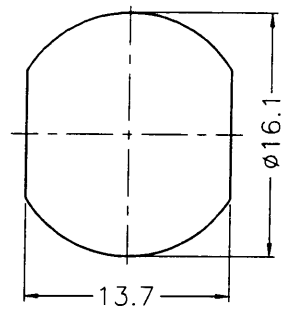

RECOMMENDED
MOUNTING HOLE
(建議架設孔)

業務部

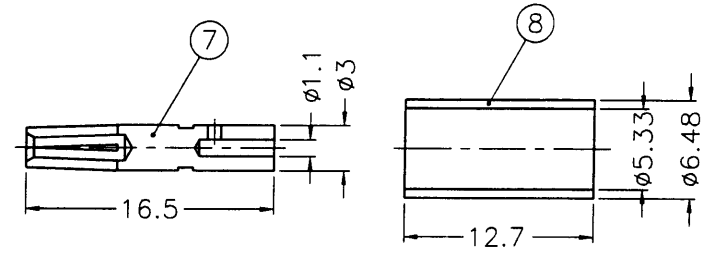
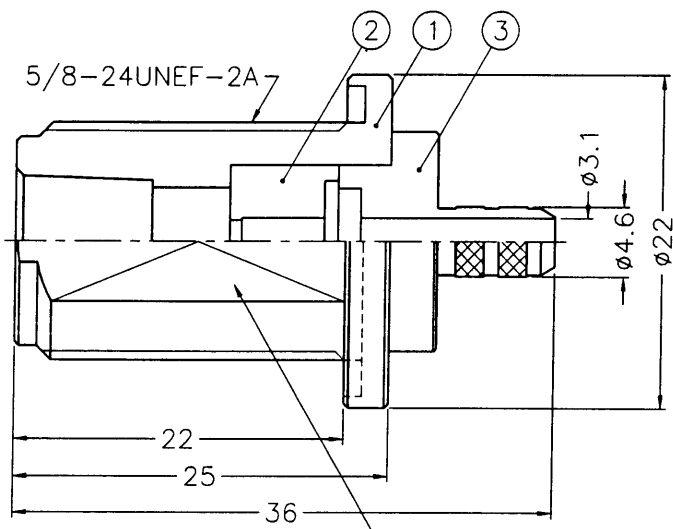
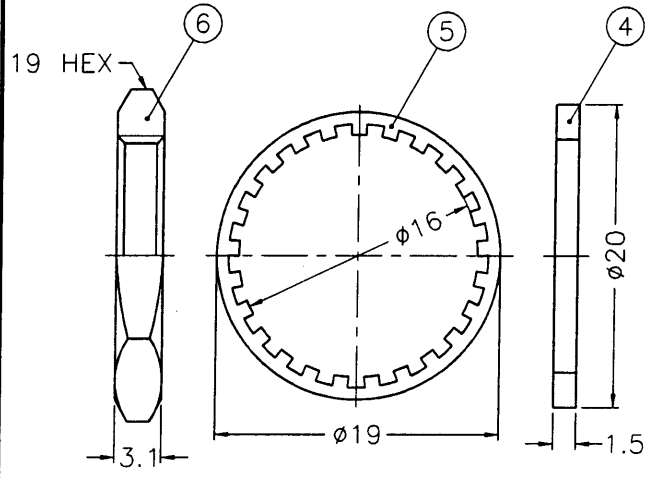

- NOTES: FINISH (PLATING THICKNESS IN MICRO-INCHES)
- BRASS PER QQ-B-626
 - BRASS PER QQ-B-613
 - NICKEL PL. 100 MIN. THICK OVER COPPER STRIKE
 - PHOSPHOR BRONZE PER QQ-B-750
 - GOLD PL. 3 MIN. THICK OVER NICKEL PL. 100 MIN. THICK OVER COPPER STRIKE
 - TEFLON MIL-P-19468

13.45 ON FLATS
(兩平面寬 13.45)

- CRIMPED FERRULE
HEX CRIMP SIZE .213"
- CRIMPED CONTACT PIN
HEX CRIMP SIZE .100"

89.4.27
設計部

89.4.
設計

NO.	DESCRIPTION	MATERIAL	FINISH	Q'TY	DRAWING NO.
8	FERRULE	COPPER	NATURAL	1	FR-648/533X 127C
7	CONTACT PIN	NOTE 4	NOTE 5	1	N7000-4-3/11
6	HEX NUT	NOTE 1	NOTE 3	1	HN19-5/8-24X31
5	LOCK WASHER	NOTE 2	NOTE 3	1	LW-19/16X06
4	GASKET	SILICONE	RED	1	GS-20/16X15
3	BARREL	NOTE 1	NOTE 3	1	N7400-3-46/31 -B
2	INSULATOR	NOTE 6	NATURAL	1	N5000-4T-50-A
1	BODY	NOTE 1	NOTE 3	1	N7400-1

DIMENSIONS ARE IN MILLIMETERS			
UNLESS OTHERWISE SPECIFIED	TOLERANCES	SCALE	2/1
0.5-6	= ±0.2	ISSUE	A
6-30	= ±0.4		
30-120	= ±0.6		
120-315	= ±1		
315-1000	= ±1.6		
1000-2000	= ±2.4		

PART NO.	
APPROVED	DATE 04-25-00'
CHECKED	DATE 04-25-00'
DRAWN	DATE 04-25-00'

Amphenol - Kai Jack	
TAINAN TAIWAN	
TITLE N BULKHEAD CRIMP JACK	
DRAWING NO. KJ-N6421A1-NT3G-58CU-50	
FILE NO. F:\DWG\N\6421A1\58CU-50\NT3G	

F
E
D
C
B
A

F
E
D
C
B
A

1 2 3 4 5 6 7 8 1185