

REVISIONS		
ISS	ZONE	DESCRIPTION\PER REQUEST\DATE
B	A-1	NO.3 WAS CHANGED\RD-DM89042201\04-22-00'
	B-1	NO.8 WAS CHANGED\RD-DM89083101\08-31-00'

業務部

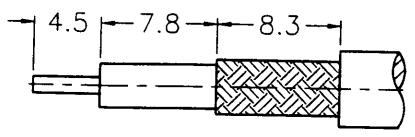

RECOMMENDED
CABLE STRIPPING DIM'S
(建議剝線尺寸)

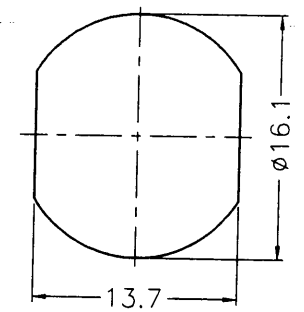

RECOMMENDED
MOUNTING HOLE
(建議架設孔)

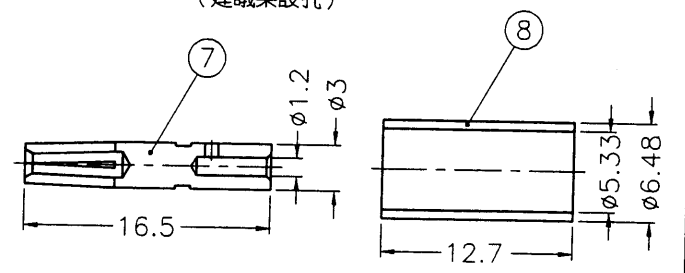
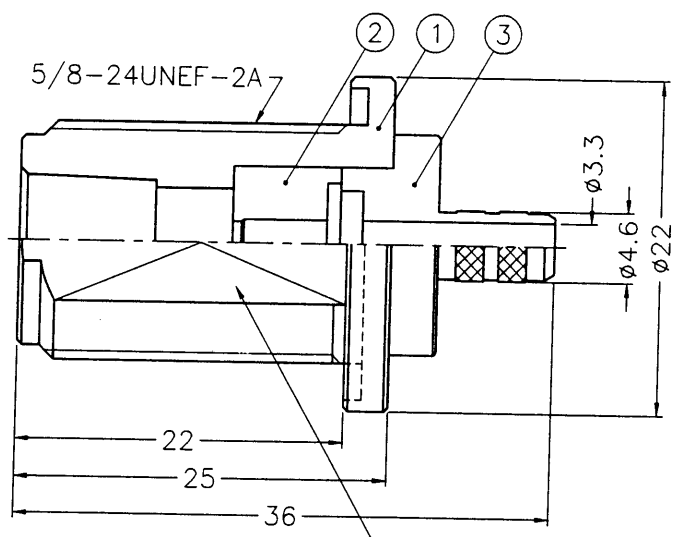
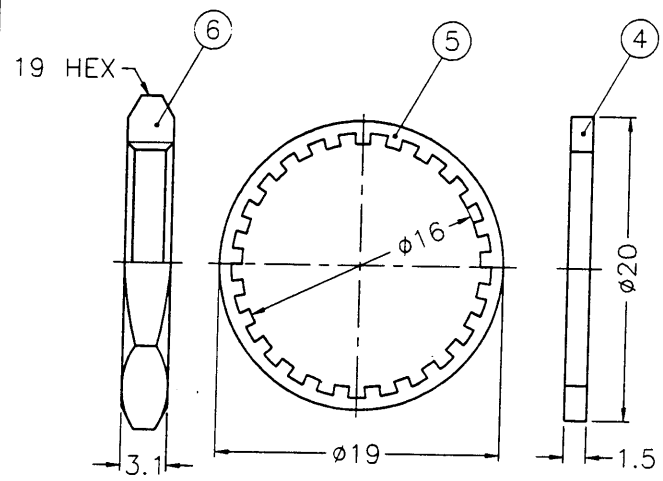

NOTES: FINISH (PLATING THICKNESS IN MICRO-INCHES)
 1. BRASS PER QQ-B-626
 2. BRASS PER QQ-B-613
 3. NICKEL PL. 100 MIN. THICK OVER COPPER STRIKE
 4. PHOSPHOR BRONZE PER QQ-B-750
 5. GOLD PL. 3 MIN. THICK OVER NICKEL PL. 100 MIN. THICK OVER COPPER STRIKE
 6. TEFLON MIL-P-19468

2000. 9. 05
設計部

1. CRIMPED FERRULE
HEX CRIMP SIZE .213"
2. CRIMPED CONTACT PIN
HEX CRIMP SIZE .100"

PART NO.					DIMENSIONS ARE IN MILLIMETERS				UNLESS OTHERWISE SPECIFIED TOLERANCES		APPROVED		TITLE		
8	FERRULE	COPPER	NOTE 3	1	FR-648/533X127C	0.5-6 = ±0.2	6-30 = ±0.4	30-120 = ±0.4	120-315 = ±1	315-1000 = ±1.6	1000-2000 = ±2.4	<p style="font-size: 24px; margin: 0;">A Jack C</p> <p style="font-size: 24px; margin: 0;">Jackey</p> <p style="font-size: 24px; margin: 0;">Joyce Y</p>		<p style="font-size: 18px; margin: 0;">Amphenol - Kai Jack</p> <p style="font-size: 12px; margin: 0;">TAINAN TAIWAN</p> <p style="font-size: 14px; margin: 0;">N BULKHEAD CRIMP JACK</p>	
7	CONTACT PIN	NOTE 4	NOTE 5	1	N7000-4-3/12	DATE		DATE		DRAWING NO.					
6	HEX NUT	NOTE 1	NOTE 3	1	HN19-5/8-24X31	DATE		DATE		FILE NO.					
5	LOCK WASHER	NOTE 2	NOTE 3	1	LW-19/16X06	DATE		DATE		F:\DWG\N\6421A1\L200-50\NT3G					
4	GASKET	SILICONE	RED	1	GS-20/16X15	DATE		DATE							
3	BARREL	NOTE 1	NOTE 3	1	N7400-3-46/33-B	DATE		DATE							
2	INSULATOR	NOTE 6	NATURAL	1	N5000-4T-50-A	DATE		DATE							
1	BODY	NOTE 1	NOTE 3	1	N7400-1	DATE		DATE							
NO.	DESCRIPTION	MATERIAL	FINISH	Q'TY	DRAWING NO.	SCALE	2/1	ISSUE	B						

F
E
D
C
B
A

F
E
D
C
B
A